

PARTS LIST FOR AZ-2-97

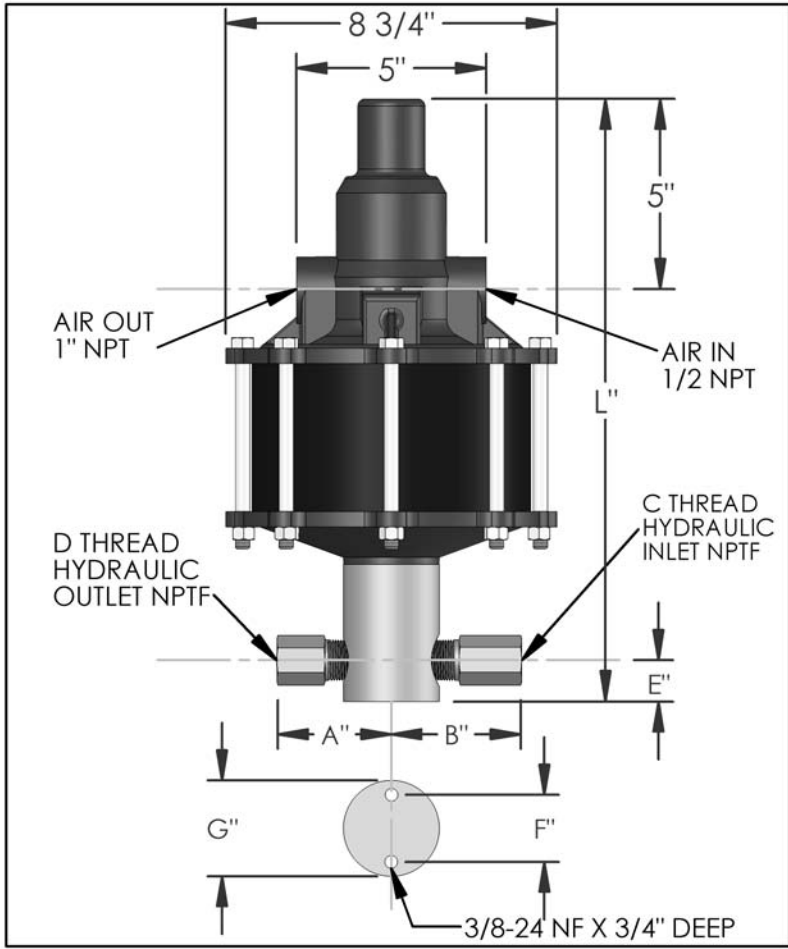

DIMENSIONS (ins./mm)							
L	A	B	C	D	E	F	G
15-3/4	3	3-3/8	1/2	1/2	7/8	1-3/4	2-1/2
400	76	86			22	44	64

HYD. PISTON DIA. (ins.)	0.688
HYD. PISTON AREA (ins.)	0.3718
VOLUME PER STROKE (ci.)	0.928

Pump may be mounted in any position. (vertical Preferred) if mounted in an inverted position, drill a 1/16" hole in head or install a drain cock to release any fluid that may accumulate.

AIR PRESSURE-PSI	10	20	30	40	50	60	70	80	90	100	110
HYDRAULIC PRESSURE-PSI	750	1,750	2,800	3,700	4,750	5,900	6,875	7,700	8,750	9,700	10,700

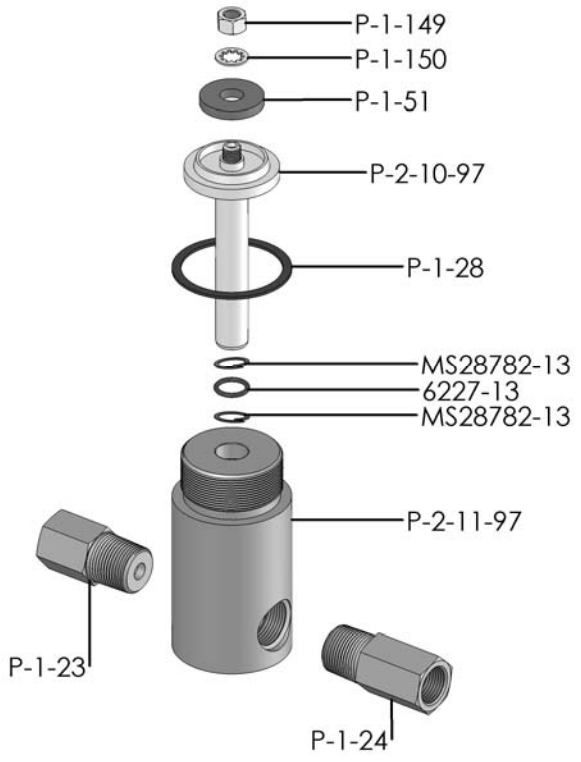

EXPLODED VIEW OF HYDRAULIC ASSEMBLY

AIR PSI		60	80	100	APPROXIMATE RATE OF DISCHARGE-CIPM
HYDRAULIC PRESSURE-PSI	0	201	220	238	
	1,000	152	180	195	
	1,250				
	1,500				
	2,000	131	159	175	
	2,500				
	3,000	113	140	156	
	3,500				
	4,000	92	122	139	
	4,500				
	5,000	67	101	128	
	6,000	0	82	112	
	7,000		51	98	
	8,000		0	79	
	9,000			46	
	10,000			0	

AZ-2 MODEL PUMP / PARTS LIST

EXPLODED VIEW OF AIR MOTOR

P-2-113

