

PARTS LIST FOR AZ-2-60SF

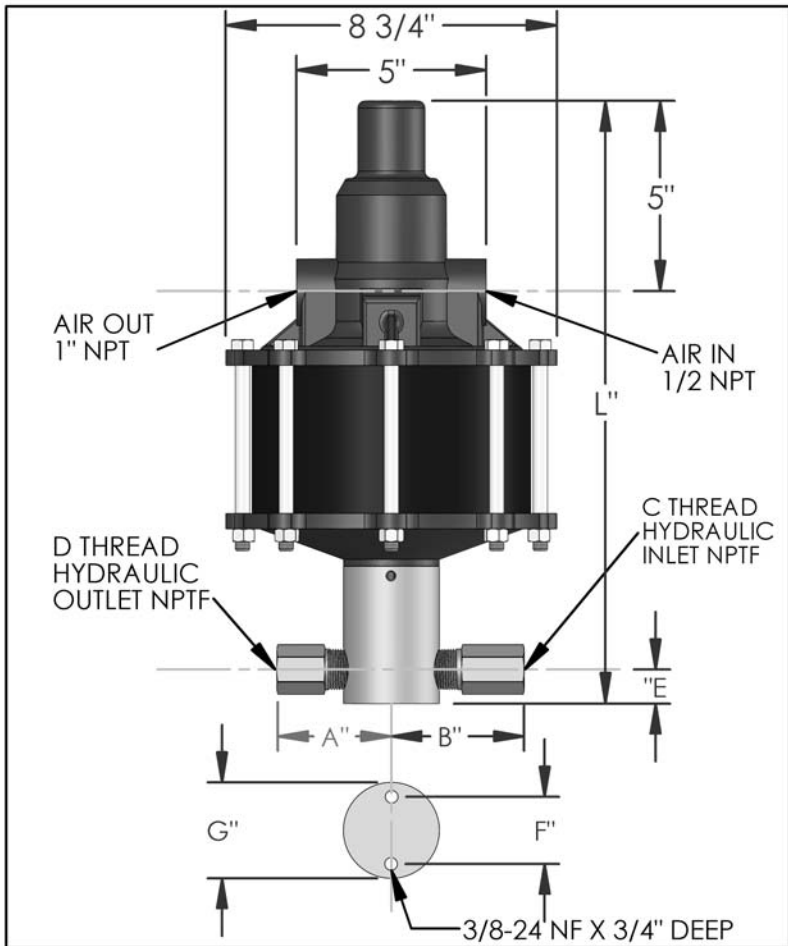

DIMENSIONS (ins./mm)							
L	A	B	C	D	E	F	G
15-3/4	3	3-3/8	1/2	1/2	7/8	1-3/4	2-1/2
400	76	86			22	44	64

HYD. PISTON DIA. (ins.)	0.875
HYD. PISTON AREA (ins.)	0.6013
VOLUME PER STROKE (ci.)	1.50

Pump may be mounted in any position. (vertical Preferred) if mounted in an inverted position, drill a 1/16" hole in head or install a drain cock to release any fluid that may accumulate.

AIR PRESSURE-PSI	10	20	30	40	50	60	70	80	90	100	110
HYDRAULIC PRESSURE-PSI	450	1,050	1,700	2,275	2,900	3,500	4,100	4,650	5,200	6,000	6,600

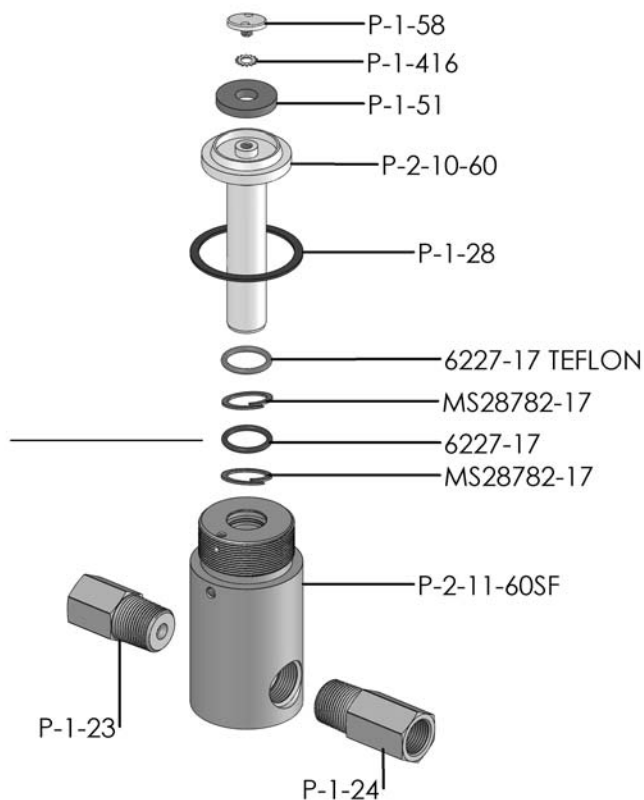

EXPLODED VIEW OF HYDRAULIC ASSEMBLY

AIR PSI		60	80	100	APPROXIMATE RATE OF DISCHARGE-CIPM
HYDRAULIC PRESSURE-PSI	0	317	366	378	
	250				
	500				
	750				
	1,000	226	265	293	
	1,250				
	1,500				
	1,750				
	2,000	180	229	256	
	2,500				
	3,000	110	179	214	
	3,500	0	159	189	
	4,000		125	168	
	4,500		58	149	
	5,000		0	132	
	6,000			0	

AZ-2 MODEL PUMP / PARTS LIST

EXPLODED VIEW OF AIR MOTOR

P-2-113

