

# PARTS LIST FOR AZ-2-60

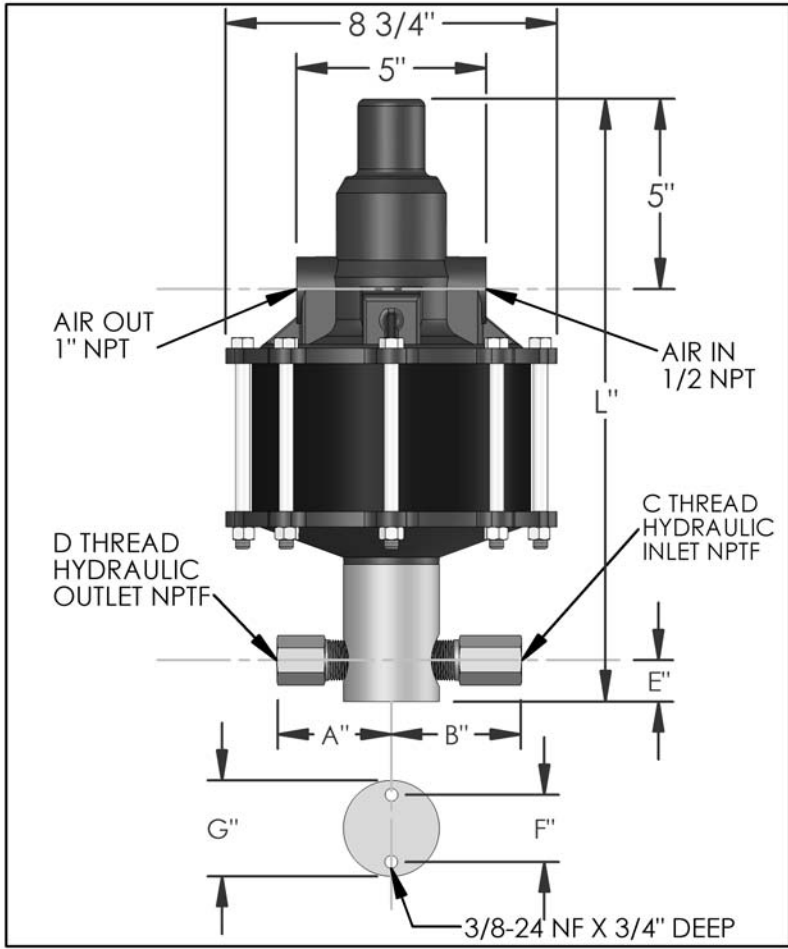

DIMENSIONS (ins./mm)							
L	A	B	C	D	E	F	G
15-3/4	3	3-3/8	1/2	1/2	7/8	1-3/4	2-1/2
400	76	86			22	44	64

HYD. PISTON DIA. (ins.)	0.875
HYD. PISTON AREA (ins.)	0.6013
VOLUME PER STROKE (ci.)	1.5

Pump may be mounted in any position. (vertical Preferred) if mounted in an inverted position, drill a 1/16" hole in head or install a drain cock to release any fluid that may accumulate.

AIR PRESSURE-PSI	10	20	30	40	50	60	70	80	90	100	110
HYDRAULIC PRESSURE-PSI	450	1,050	1,700	2,275	2,900	3,500	4,100	4,650	5,200	6,000	6,600

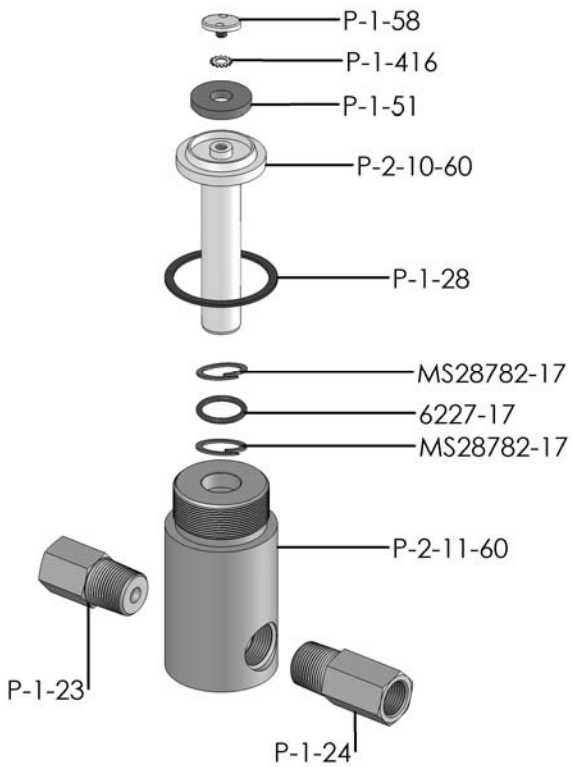

EXPLODED VIEW OF HYDRAULIC ASSEMBLY

HYDRAULIC PRESSURE-PSI	AIR PSI	60	80	100	APPROXIMATE RATE OF DISCHARGE-CIPM
	0	317	366	378	
250					
500					
750					
1,000	226	265	293		
1,250					
1,500					
1,750					
2,000	180	229	256		
2,500					
3,000	110	179	214		
3,500	0	159	189		
4,000		125	168		
4,500		58	149		
5,000		0	132		
6,000			0		

# AZ-2 MODEL PUMP / PARTS LIST

## EXPLODED VIEW OF AIR MOTOR

P-2-113

