

PARTS LIST FOR AZ-2-458SF

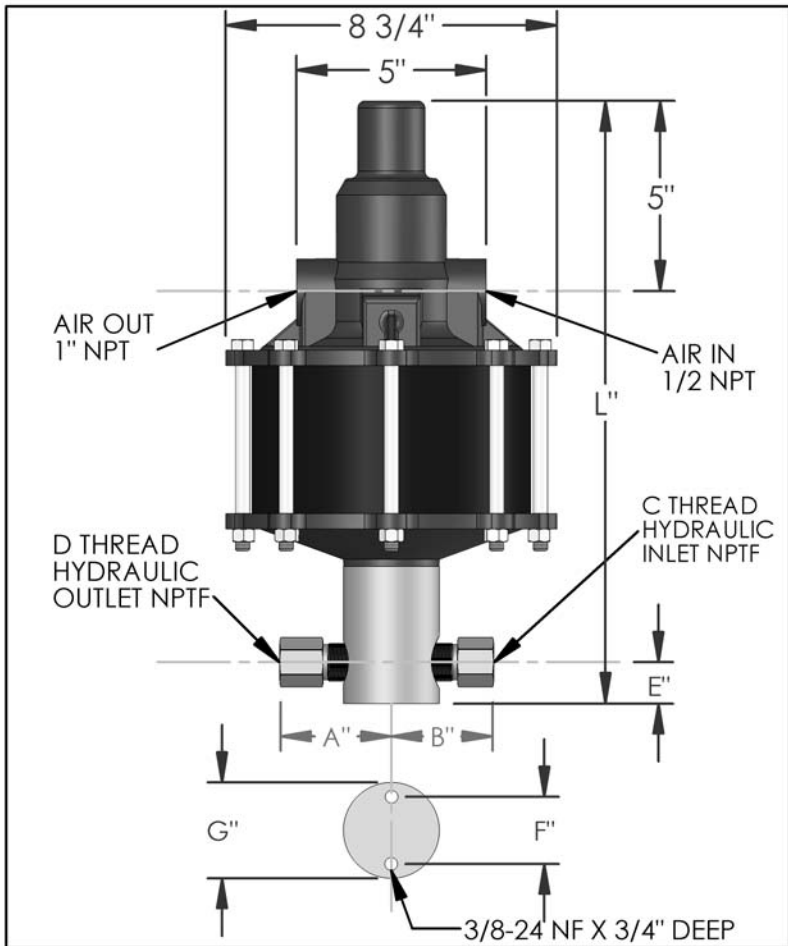

DIMENSIONS (ins./mm)							
L	A	B	C	D	E	F	G
16-1/8	2-1/2	2-5/16	3/8	3/8	7/8	1-3/4	2-1/2
410	64	59			22	44	64

HYD. PISTON DIA. (ins.)	0.313
HYD. PISTON AREA (ins.)	0.0769
VOLUME PER STROKE (ci.)	0.192

Pump may be mounted in any position. (vertical Preferred) if mounted in an inverted position, drill a 1/16" hole in head or install a drain cock to release any fluid that may accumulate.

AIR PRESSURE-PSI	10	20	30	40	50	60	70	80	90	100	110
HYDRAULIC PRESSURE-PSI	4,000	8,800	13,700	18,000	22,500	27,000	31,500	36,500	41,400	45,800	50,300

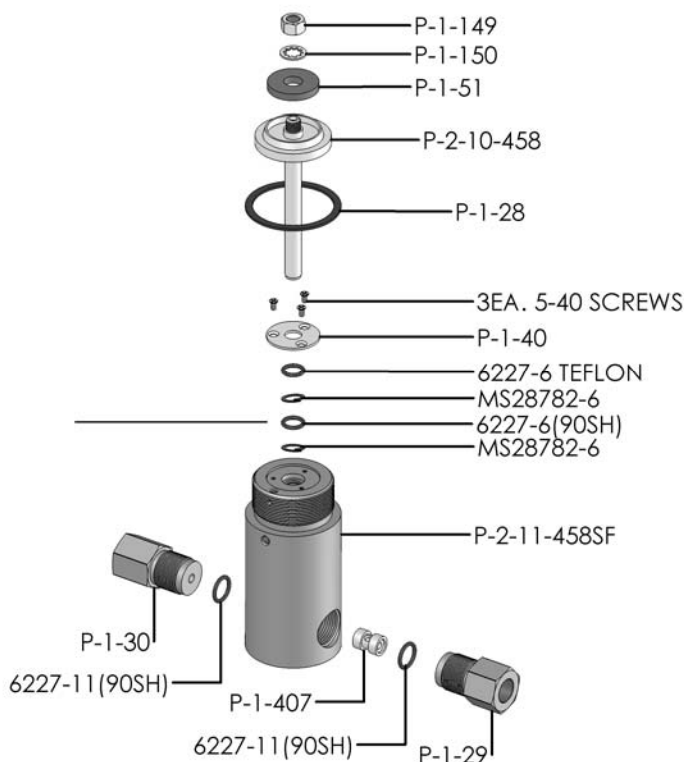

EXPLODED VIEW OF HYDRAULIC ASSEMBLY

HYDRAULIC PRESSURE-PSI	AIR PSI			APPROXIMATE RATE OF DISCHARGE-CIPM
	60	80	100	
0	40	43	46	
4,000				
4,500				
5,000	34	38	40	
6,000				
7,000				
8,000				
9,000				
10,000	28	33	35	
12,500				
15,000	24	29	31	
20,000	21	24	27	
25,000	14	21	24	
30,000	0	16	21	
40,000		0	14	
50,000			0	

AZ-2 MODEL PUMP / PARTS LIST

EXPLODED VIEW OF AIR MOTOR

P-2-113

