

PARTS LIST FOR AZ-2-458DS

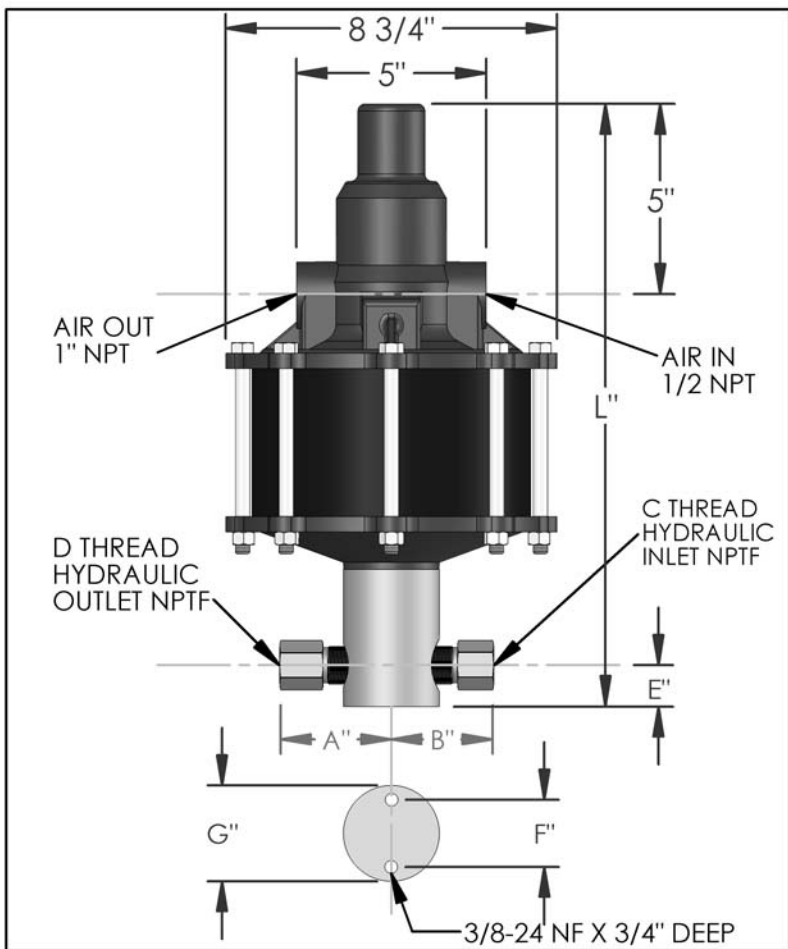

| DIMENSIONS (ins./mm) | | | | | | | |
|----------------------|-------|-----|-----|-----|-----|-------|-------|
| L | A | B | C | D | E | F | G |
| 16-1/8 | 2-1/2 | 4 | 3/8 | 3/8 | 7/8 | 1-3/4 | 2-1/2 |
| 410 | 64 | 102 | | | 22 | 44 | 64 |

| | |
|-------------------------|--------|
| HYD. PISTON DIA. (ins.) | 0.313 |
| HYD. PISTON AREA (ins.) | 0.0769 |
| VOLUME PER STROKE (ci.) | 0.192 |

Pump may be mounted in any position. (vertical Preferred) if mounted in an inverted position, drill a 1/16" hole in head or install a drain cock to release any fluid that may accumulate.

| AIR PRESSURE-PSI | 10 | 20 | 30 | 40 | 50 | 60 | 70 | 80 | 90 | 100 | 110 |
|------------------------|-------|-------|--------|--------|--------|--------|--------|--------|--------|--------|--------|
| HYDRAULIC PRESSURE-PSI | 4,000 | 8,800 | 13,700 | 18,000 | 22,500 | 27,000 | 31,500 | 36,500 | 41,400 | 45,800 | 50,300 |

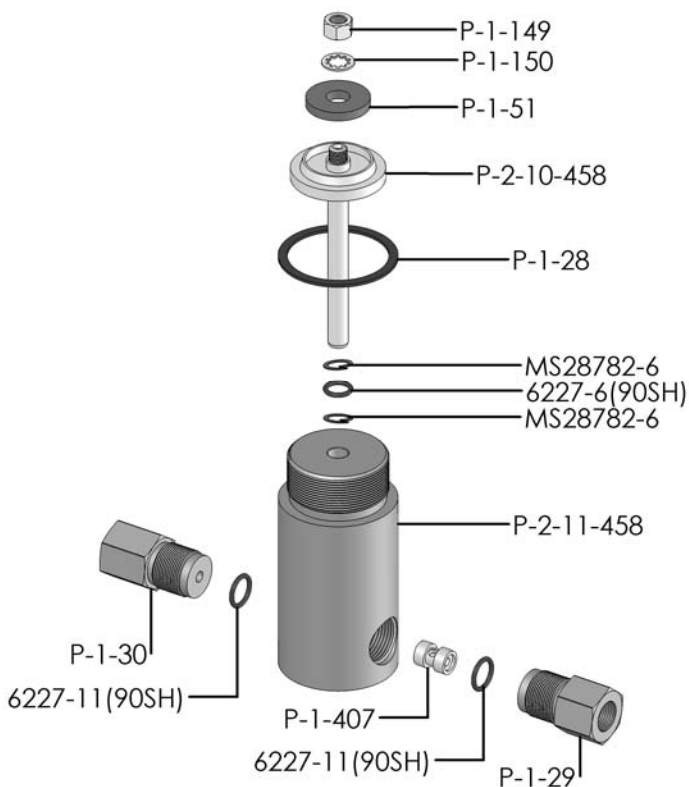

EXPLODED VIEW OF HYDRAULIC ASSEMBLY

| AIR PSI | | 60 | 80 | 100 | APPROXIMATE RATE OF DISCHARGE-CIPM |
|------------------------|--------|----|----|-----|------------------------------------|
| HYDRAULIC PRESSURE-PSI | 0 | 40 | 43 | 46 | |
| | 4,000 | | | | |
| | 4,500 | | | | |
| | 5,000 | 34 | 38 | 40 | |
| | 6,000 | | | | |
| | 7,000 | | | | |
| | 8,000 | | | | |
| | 9,000 | | | | |
| | 10,000 | 28 | 33 | 35 | |
| | 12,500 | | | | |
| | 15,000 | 24 | 29 | 31 | |
| | 20,000 | 21 | 24 | 27 | |
| | 25,000 | 14 | 21 | 24 | |
| | 30,000 | 0 | 16 | 21 | |
| | 40,000 | | 0 | 14 | |
| | 50,000 | | | 0 | |

AZ-2 MODEL PUMP / PARTS LIST

EXPLODED VIEW OF AIR MOTOR

P-2-113DS

