

PARTS LIST FOR AZ-2-36SF

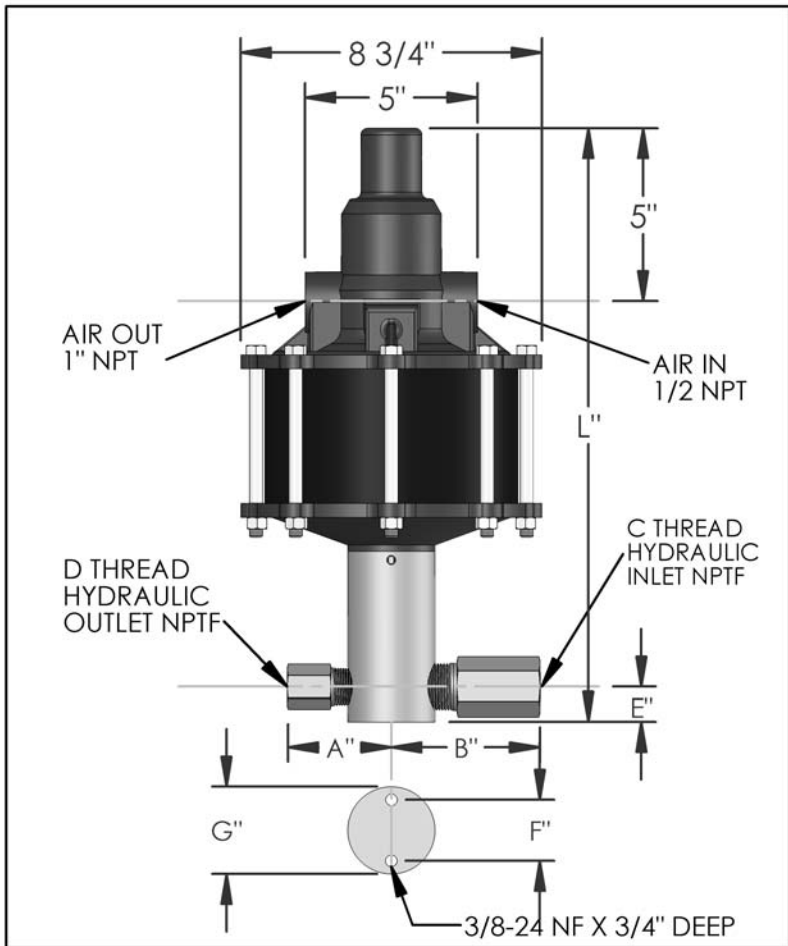

DIMENSIONS (ins./mm)							
L	A	B	C	D	E	F	G
17-1/16	3	4	1"	1/2	1	1-3/4	2-1/2
433	76	102			25	44	64

HYD. PISTON DIA. (ins.)	1.125
HYD. PISTON AREA (ins.)	0.994
VOLUME PER STROKE (ci.)	2.49

Pump may be mounted in any position. (vertical Preferred) if mounted in an inverted position, drill a 1/16" hole in head or install a drain cock to release any fluid that may accumulate.

AIR PRESSURE-PSI	10	20	30	40	50	60	70	80	90	100	110
HYDRAULIC PRESSURE-PSI	250	625	1,025	1,400	1,800	2,150	2,500	2,850	3,250	3,600	3,950

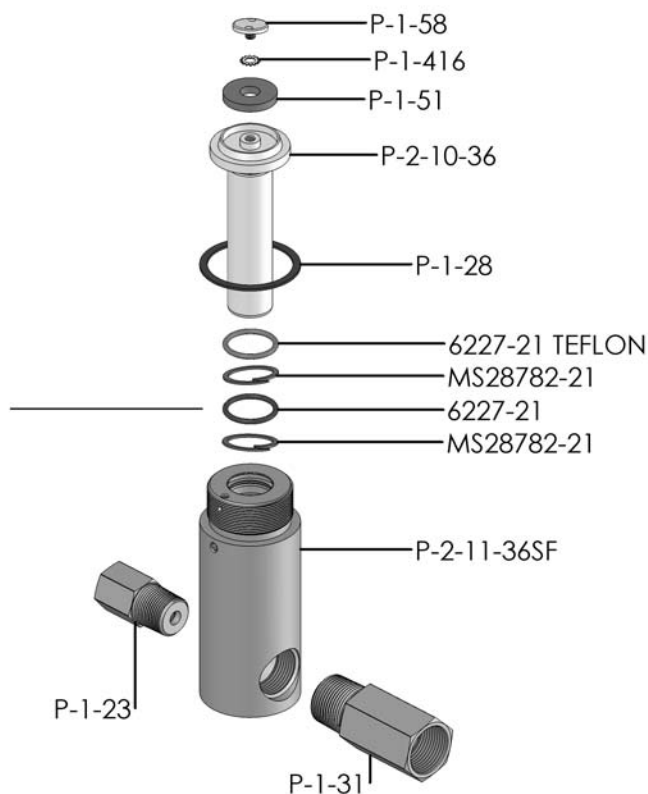

EXPLODED VIEW OF HYDRAULIC ASSEMBLY

AIR PSI		60	80	100	APPROXIMATE RATE OF DISCHARGE-CIPM
HYDRAULIC PRESSURE-PSI	0	500	573	622	
	250				
	500	409	464	525	
	750				
	1,000	336	411	445	
	1,250				
	1,500	253	329	381	
	1,750				
	2,000	131	277	332	
	2,500	0	188	273	
	3,000		0	200	
	3,500			45	
	4,000			0	
	4,500				
	5,000				
6,000					

AZ-2 MODEL PUMP / PARTS LIST

EXPLODED VIEW OF AIR MOTOR

P-2-113

