

# PARTS LIST FOR AZ-2-323

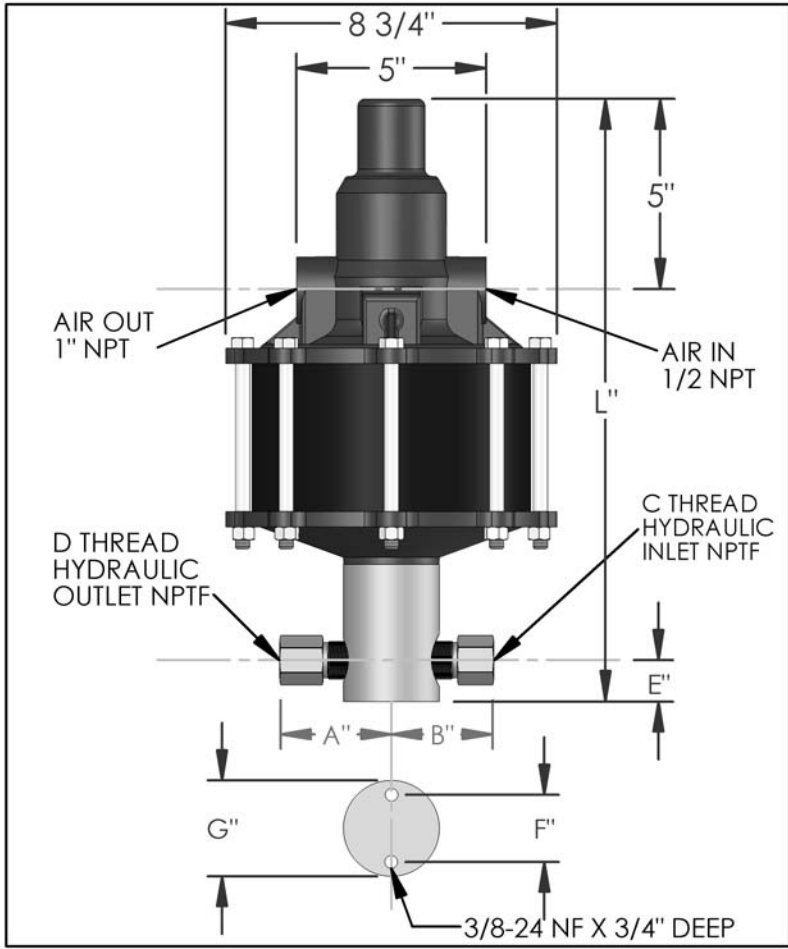

DIMENSIONS (ins./mm)							
L	A	B	C	D	E	F	G
16-1/8	2-1/2	2-5/16	3/8	3/8	7/8	1-3/4	2-1/2
410	64	102			22	44	64

HYD. PISTON DIA. (ins.)	0.375
HYD. PISTON AREA (ins.)	0.1104
VOLUME PER STROKE (ci.)	0.276

Pump may be mounted in any position. (vertical Preferred) if mounted in an inverted position, drill a 1/16" hole in head or install a drain cock to release any fluid that may accumulate.

AIR PRESSURE-PSI	10	20	30	40	50	60	70	80	90	100	110
HYDRAULIC PRESSURE-PSI	3,000	6,000	9,500	12,600	16,000	19,100	22,300	25,600	29,000	32,300	35,600

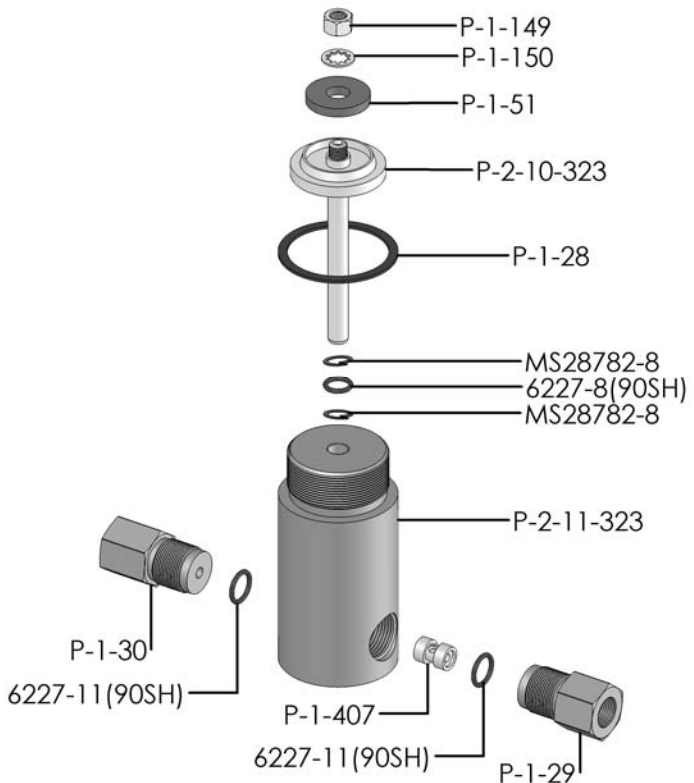

EXPLODED VIEW OF HYDRAULIC ASSEMBLY

HYDRAULIC PRESSURE-PSI	AIR PSI			APPROXIMATE RATE OF DISCHARGE-CIPM
	60	80	100	
0	61	65	70	
3,000	49	57	59	
4,000				
4,500				
5,000				
6,000	43	51	54	
7,000				
8,000				
9,000	38	46	49	
10,000				
12,500	31	40	44	
15,000	27	37	40	
20,000	0	30	34	
25,000		10	28	
30,000		0	14	
40,000			0	

# AZ-2 MODEL PUMP / PARTS LIST

## EXPLODED VIEW OF AIR MOTOR

P-2-113

