

# PARTS LIST FOR AZ-2-237SF

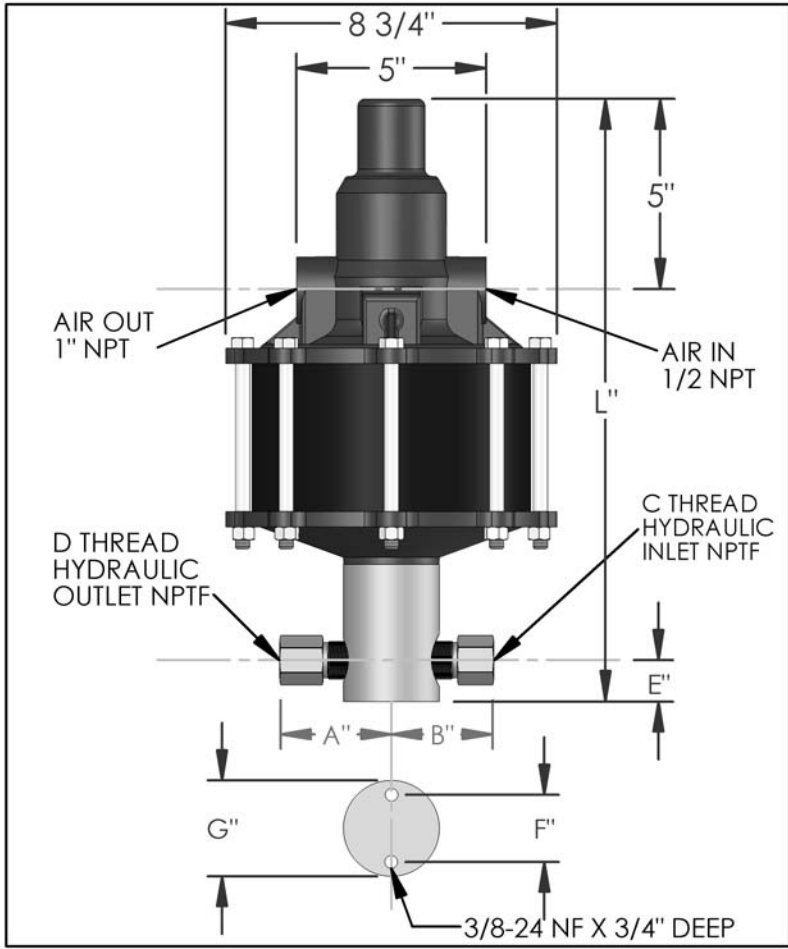

DIMENSIONS (ins./mm)							
L	A	B	C	D	E	F	G
16-1/8	2-1/2	2-5/16	3/8	3/8	7/8	1-3/4	2-1/2
410	64	59			22	44	64

HYD. PISTON DIA. (ins.)	0.438
HYD. PISTON AREA (ins.)	0.1507
VOLUME PER STROKE (ci.)	0.376

Pump may be mounted in any position. (vertical Preferred) if mounted in an inverted position, drill a 1/16" hole in head or install a drain cock to release any fluid that may accumulate.

AIR PRESSURE-PSI	10	20	30	40	50	60	70	80	90	100	110
HYDRAULIC PRESSURE-PSI	1,900	4,400	6,900	9,100	11,600	14,000	16,400	18,800	21,300	23,700	26,000

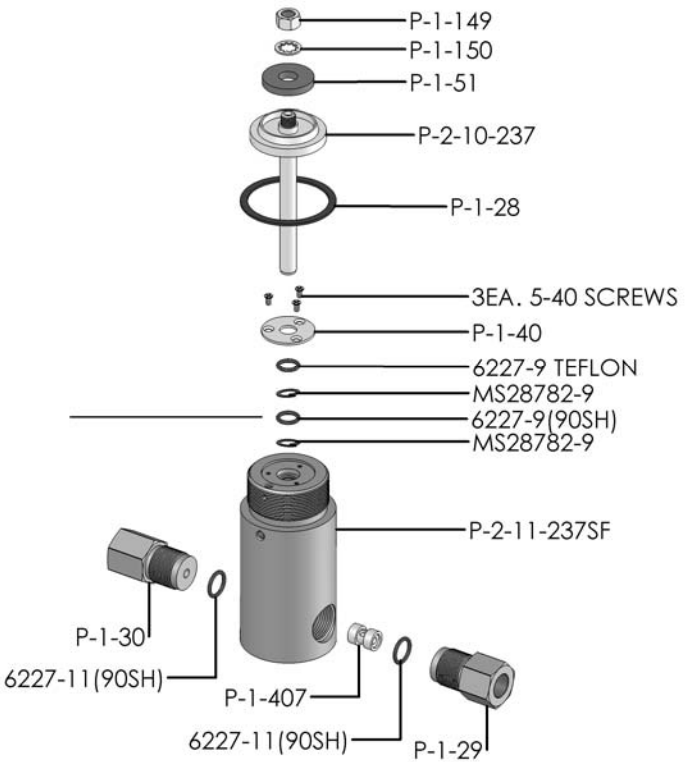

**EXPLODED VIEW OF HYDRAULIC ASSEMBLY**

AIR PSI		60	80	100	APPROXIMATE RATE OF DISCHARGE-CIPM
HYDRAULIC PRESSURE-PSI	0	79	88	98	
	1,000				
	3,000	65	74	79	
	4,000				
	5,000				
	6,000	55	65	70	
	8,000				
	9,000	45	54	62	
	10,000				
	12,500	26	45	52	
	15,000	0	38	48	
	20,000		0	36	
	25,000			0	
	30,000				
	40,000				
	50,000				

# AZ-2 MODEL PUMP / PARTS LIST

## EXPLODED VIEW OF AIR MOTOR

P-2-113

