

PARTS LIST FOR AZ-2-237

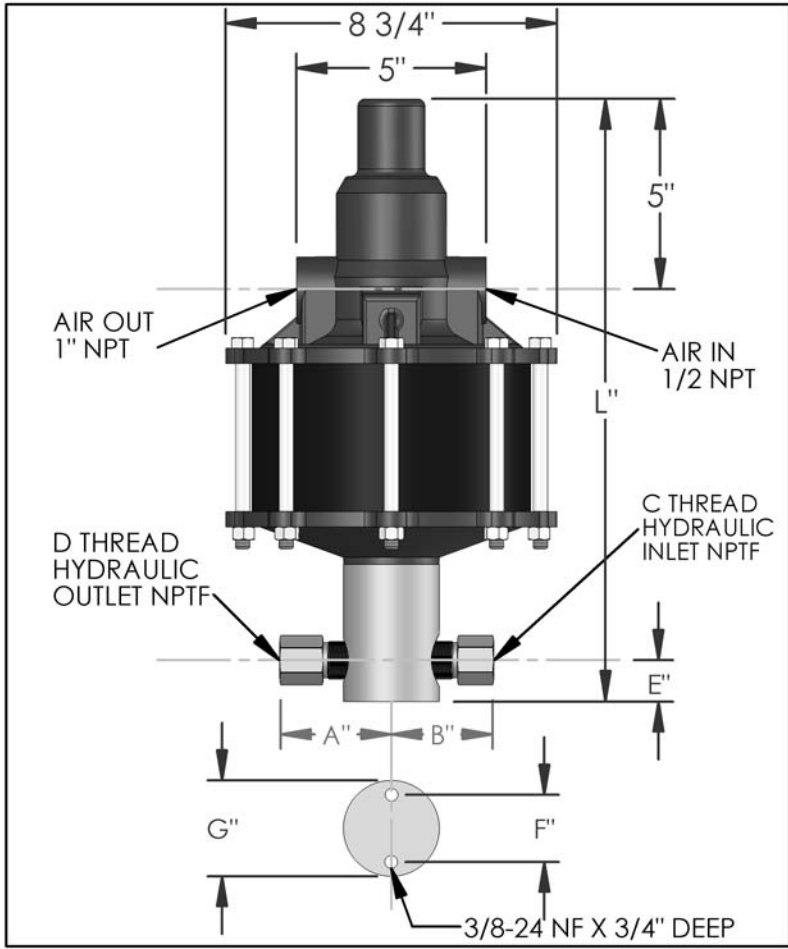

DIMENSIONS (ins./mm)							
L	A	B	C	D	E	F	G
16-1/8	2-1/2	2-5/16	3/8	3/8	7/8	1-3/4	2-1/2
410	64	59			22	44	64

HYD. PISTON DIA. (ins.)	0.438
HYD. PISTON AREA (ins.)	0.1507
VOLUME PER STROKE (ci.)	0.376

Pump may be mounted in any position. (vertical Preferred) if mounted in an inverted position, drill a 1/16" hole in head or install a drain cock to release any fluid that may accumulate.

AIR PRESSURE-PSI	10	20	30	40	50	60	70	80	90	100	110
HYDRAULIC PRESSURE-PSI	1,900	4,400	6,900	9,100	11,600	14,000	16,400	18,800	21,300	23,700	26,000

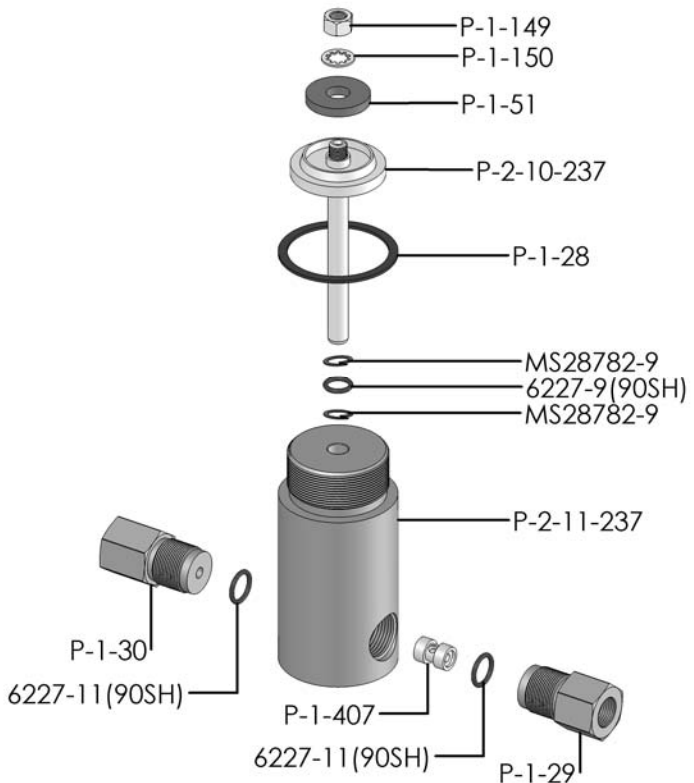

EXPLODED VIEW OF HYDRAULIC ASSEMBLY

HYDRAULIC PRESSURE-PSI	AIR PSI			APPROXIMATE RATE OF DISCHARGE-CIPM
	60	80	100	
0	79	88	98	
1,000				
3,000	65	74	79	
4,000				
5,000				
6,000	55	65	70	
8,000				
9,000	45	54	62	
10,000				
12,500	26	45	52	
15,000	0	38	48	
20,000		0	36	
25,000			0	
30,000				
40,000				
50,000				

AZ-2 MODEL PUMP / PARTS LIST

EXPLODED VIEW OF AIR MOTOR

P-2-113

