

PARTS LIST FOR AZ-2-180LPS

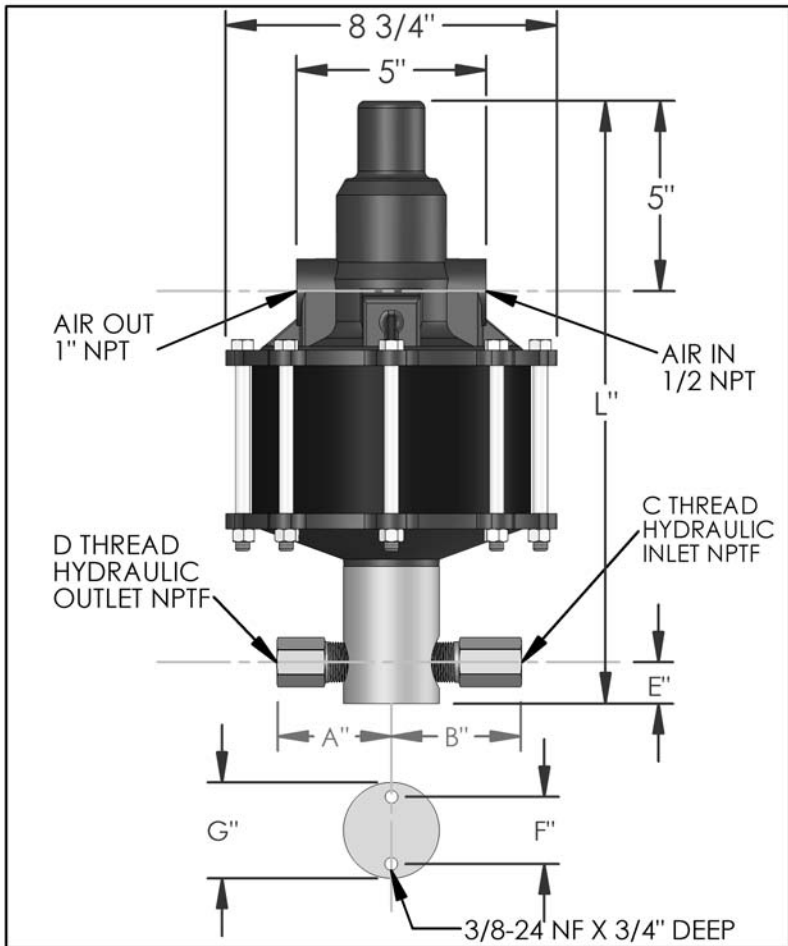

DIMENSIONS (ins./mm)							
L	A	B	C	D	E	F	G
15-3/4	3	3-3/8	1/2	1/2	7/8	1-3/4	2-1/2
400	76	86			22	44	64

HYD. PISTON DIA. (ins.)	0.500
HYD. PISTON AREA (ins.)	0.1963
VOLUME PER STROKE (ci.)	0.491

Pump may be mounted in any position. (vertical Preferred) if mounted in an inverted position, drill a 1/16" hole in head or install a drain cock to release any fluid that may accumulate.

AIR PRESSURE-PSI	10	20	30	40	50	60	70	80	90	100	110
HYDRAULIC PRESSURE-PSI	1,500	3,200	5,200	7,100	9,000	10,800	12,500	14,500	16,300	18,000	19,800

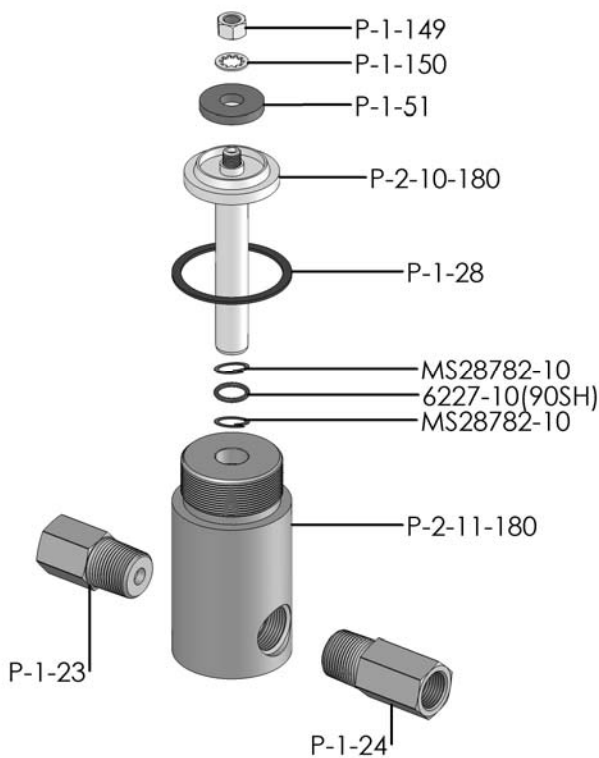

EXPLODED VIEW OF HYDRAULIC ASSEMBLY

AIR PSI		60	80	100	APPROXIMATE RATE OF DISCHARGE-CIPM
HYDRAULIC PRESSURE-PSI	0	101	122	128	
	2,000				
	2,500	77	92	98	
	3,000				
	3,500				
	4,000				
	4,500				
	5,000	64	77	85	
	6,000				
	7,000				
	8,000	47	63	73	
	9,000				
	10,000	27	52	64	
	12,500	0	38	54	
	15,000		0	46	
20,000			0		

AZ-2 MODEL PUMP / PARTS LIST

EXPLODED VIEW OF AIR MOTOR

P-2-113LPS

