

PARTS LIST FOR AZ-1-86

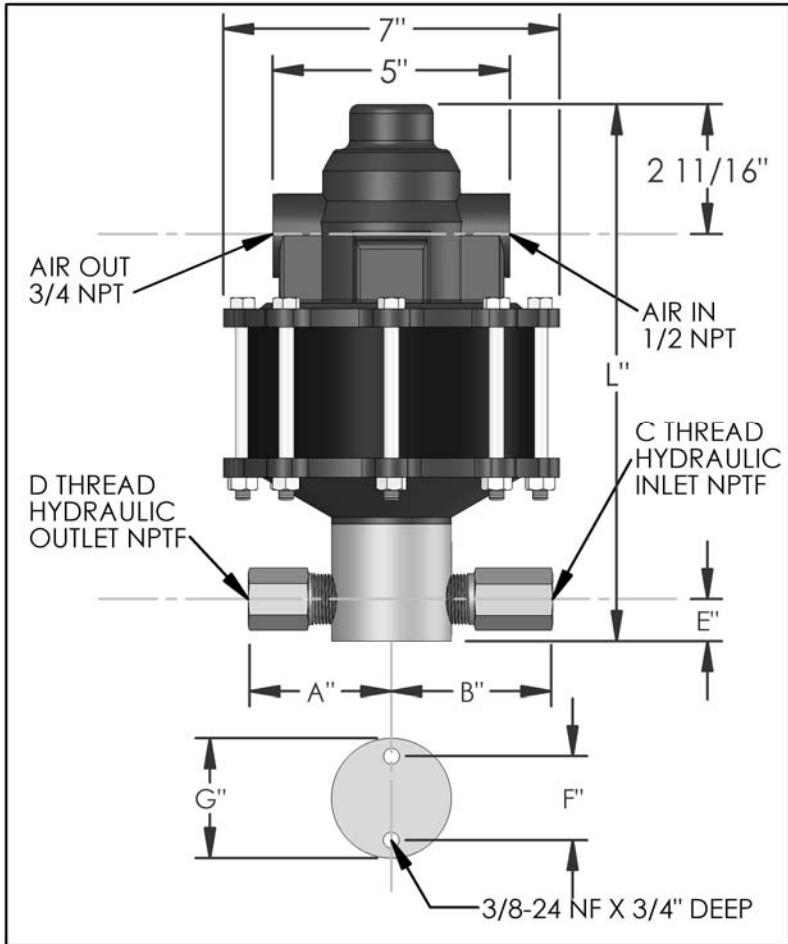

DIMENSIONS (ins./mm)							
L	A	B	C	D	E	F	G
10-7/8	3	3-3/8	1/2	1/2	7/8	1-3/4	2-1/2
276	76	86			22	44	64

HYD. PISTON DIA. (ins.)	0.563
HYD. PISTON AREA (ins.)	0.2489
VOLUME PER STROKE (ci.)	.31

Pump may be mounted in any position. (vertical Preferred) if mounted in an inverted position, drill a 1/16" hole in head or install a drain cock to release any fluid that may accumulate.

AIR PRESSURE-PSI	10	20	30	40	50	60	70	80	90	100
HYDRAULIC PRESSURE-PSI	800	1,700	2,600	3,400	4,400	5,100	6,000	6,900	7,800	8,600

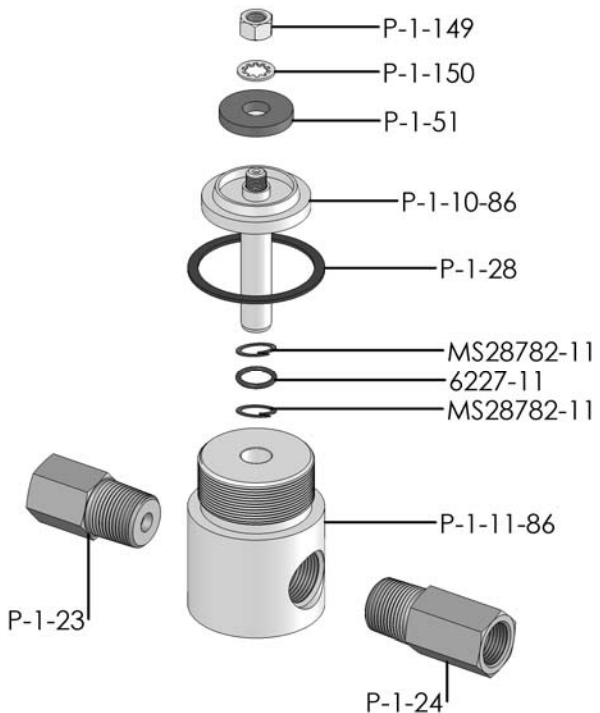

EXPLODED VIEW OF HYDRAULIC ASSEMBLY

HYDRAULIC PRESSURE-PSI	AIR PSI	60	80	100	APPROXIMATE RATE OF DISCHARGE-CIPM
		0	115	160	
	1,000	87	94	100	
	1,250				
	1,500				
	1,750				
	2,000	80	87	93	
	2,500				
	3,000	68	77	83	
	3,500				
	4,000	49	62	73	
	4,500	35	59	70	
	5,000	0	56	65	
	6,000		42	59	
	7,000		0	49	
	8,000			29	
	9,000			0	

AZ-1 MODEL PUMP / PARTS LIST

EXPLODED VIEW OF AIR MOTOR

P-1-113

