

PARTS LIST FOR AZ-1-70SF

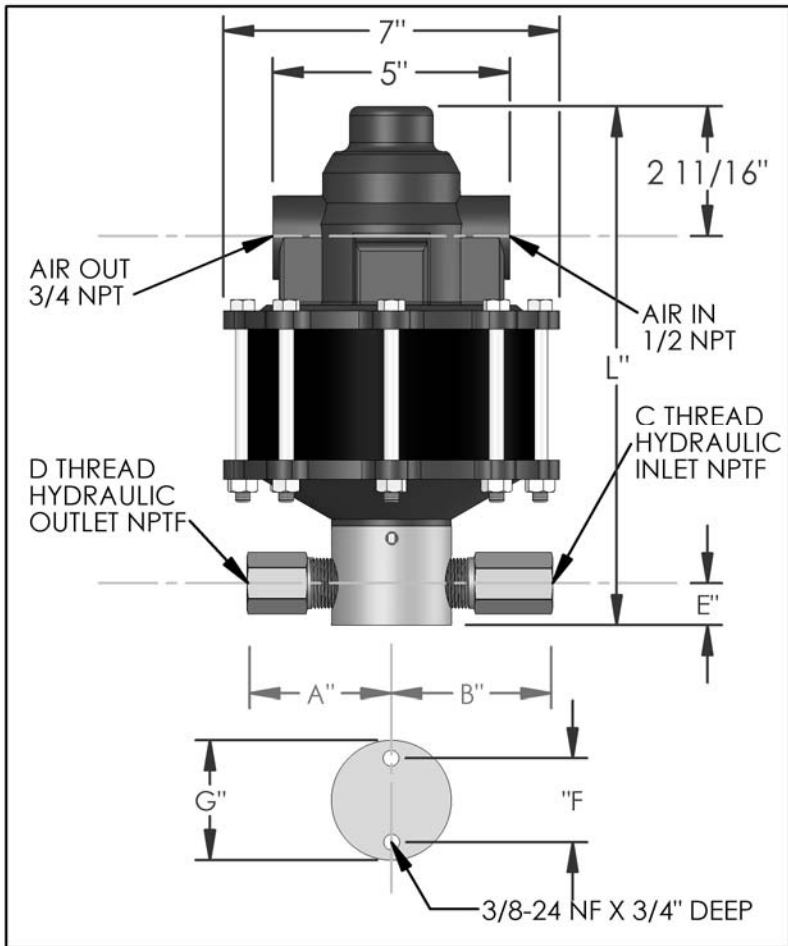

DIMENSIONS (ins./mm)							
L	A	B	C	D	E	F	G
10-7/8	3	3-3/8	1/2	1/2	7/8	1-3/4	2-1/2
276	76	86			22	44	64

HYD. PISTON DIA. (ins.)	0.625
HYD. PISTON AREA (ins.)	0.3068
VOLUME PER STROKE (ci.)	0.3835

Pump may be mounted in any position. (vertical Preferred) if mounted in an inverted position, drill a 1/16" hole in head or install a drain cock to release any fluid that may accumulate.

AIR PRESSURE-PSI	10	20	30	40	50	60	70	80	90	100
HYDRAULIC PRESSURE-PSI	500	1,175	1,950	2,600	3,350	4,100	4,900	5,600	6,350	7,000

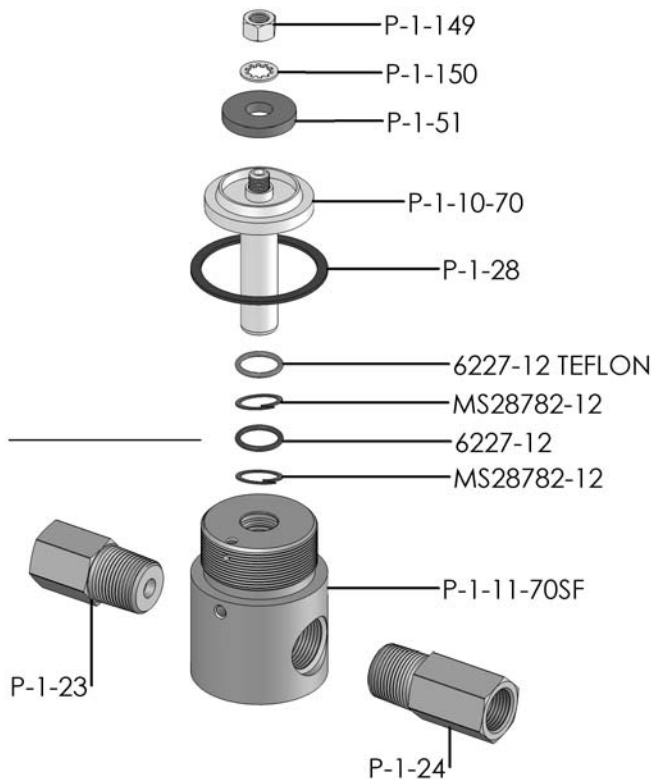

EXPLODED VIEW OF HYDRAULIC ASSEMBLY

AIR PSI		60	80	100	APPROXIMATE RATE OF DISCHARGE-CIPM
HYDRAULIC PRESSURE-PSI	0	143	156	181	
	500				
	750				
	1,000	99	116	128	
	1,250				
	1,500				
	1,750				
	2,000	82	105	113	
	2,500				
	3,000	70	88	98	
	3,500				
	4,000	35	74	89	
	4,500	0	52	79	
	5,000		34	76	
	6,000		0	57	
	7,000			0	

AZ-1 MODEL PUMP / PARTS LIST

EXPLODED VIEW OF AIR MOTOR

P-1-113

