

PARTS LIST FOR AZ-1-58SF

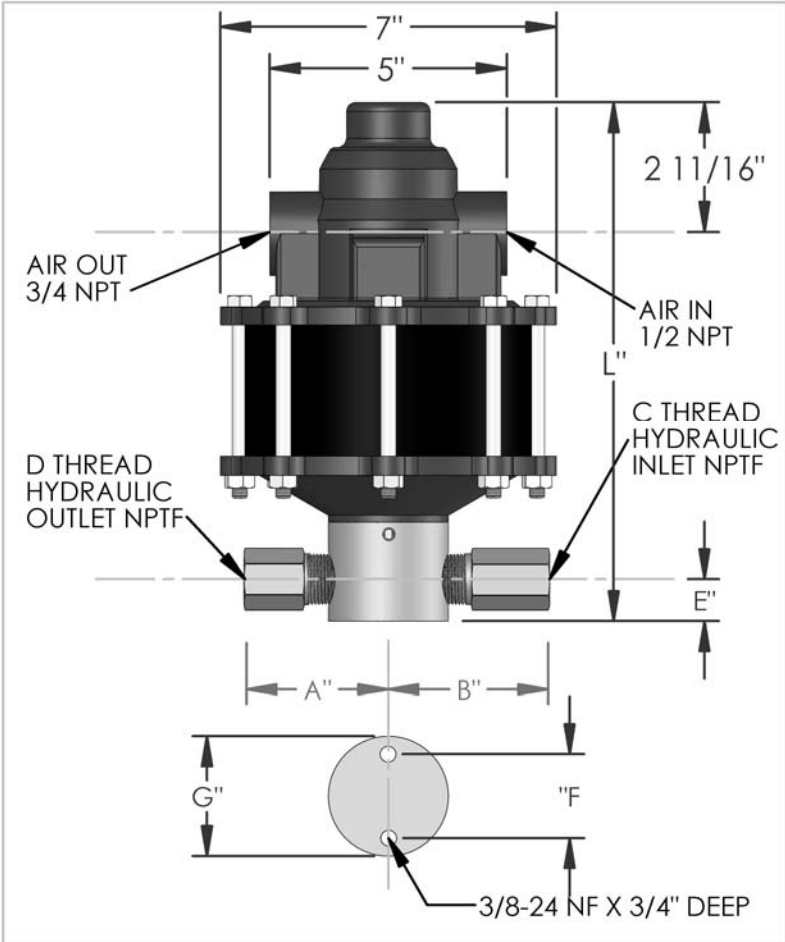

DIMENSIONS (ins./mm)							
L	A	B	C	D	E	F	G
10-7/8	3	3-3/8	1/2	1/2	7/8	1-3/4	2-1/2
276	76	86			22	44	64

HYD. PISTON DIA. (ins.)	0.688
HYD. PISTON AREA (ins.)	0.3718
VOLUME PER STROKE (ci.)	0.464

Pump may be mounted in any position. (vertical Preferred) if mounted in an inverted position, drill a 1/16" hole in head or install a drain cock to release any fluid that may accumulate.

AIR PRESSURE-PSI	10	20	30	40	50	60	70	80	90	100
HYDRAULIC PRESSURE-PSI	400	1,000	1,700	2,200	2,900	3,400	4,000	4,600	5,200	5,800

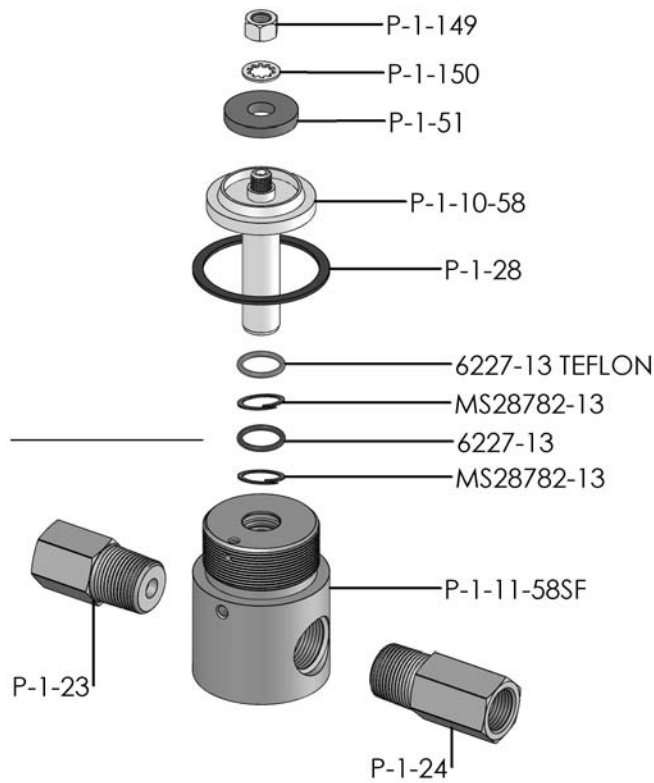

EXPLODED VIEW OF HYDRAULIC ASSEMBLY

HYDRAULIC PRESSURE-PSI	AIR PSI	60	80	100	APPROXIMATE RATE OF DISCHARGE-CIPM
	0	186	200	217	
250					
500					
750					
1,000	119	137	153		
1,250					
1,500					
1,750					
2,000	99	117	137		
2,500					
3,000	63	96	113		
3,500	0	84	104		
4,000		67	95		
4,500		0	79		
5,000			62		
6,000			0		

AZ-1 MODEL PUMP / PARTS LIST

EXPLODED VIEW OF AIR MOTOR

P-1-113

