

PARTS LIST FOR AZ-1-425SF

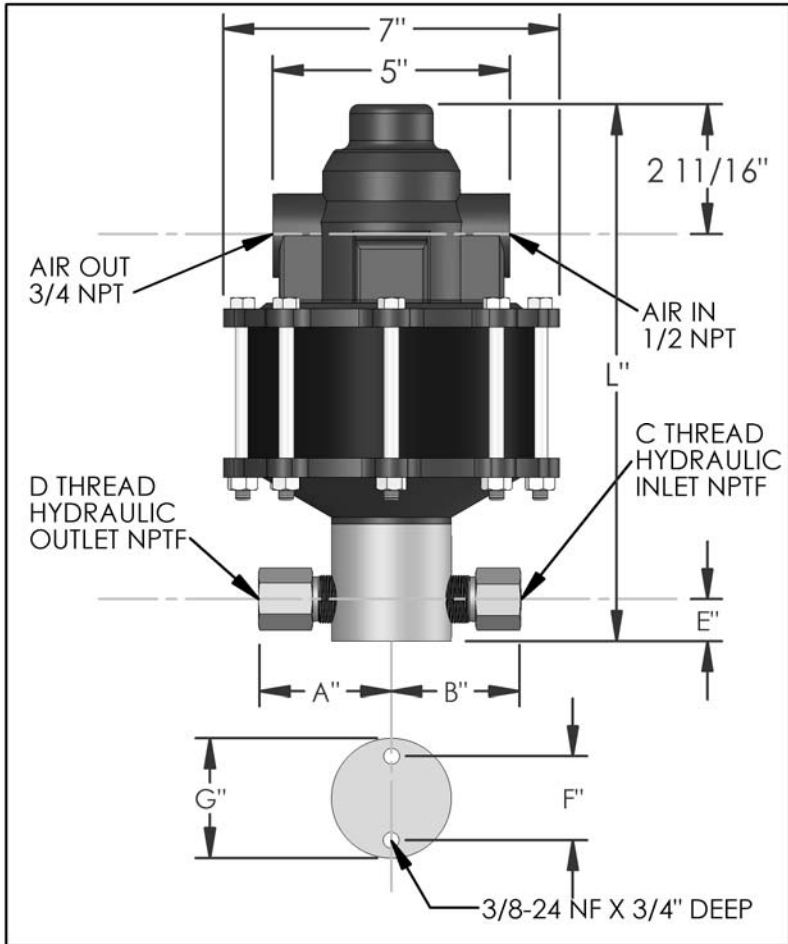

DIMENSIONS (ins./mm)							
L	A	B	C	D	E	F	G
11-1/4	2-1/2	2-5/16	3/8	3/8	7/8	1-3/4	2-1/2
286	64	59			22	44	64

HYD. PISTON DIA. (ins.)	0.250
HYD. PISTON AREA (ins.)	0.0491
VOLUME PER STROKE (ci.)	0.061

Pump may be mounted in any position. (vertical Preferred) if mounted in an inverted position, drill a 1/16" hole in head or install a drain cock to release any fluid that may accumulate.

AIR PRESSURE-PSI	10	20	30	40	50	60	70	80	90	100
HYDRAULIC PRESSURE-PSI	5,000	8,000	12,500	16,500	21,000	25,500	30,000	34,000	38,000	42,500

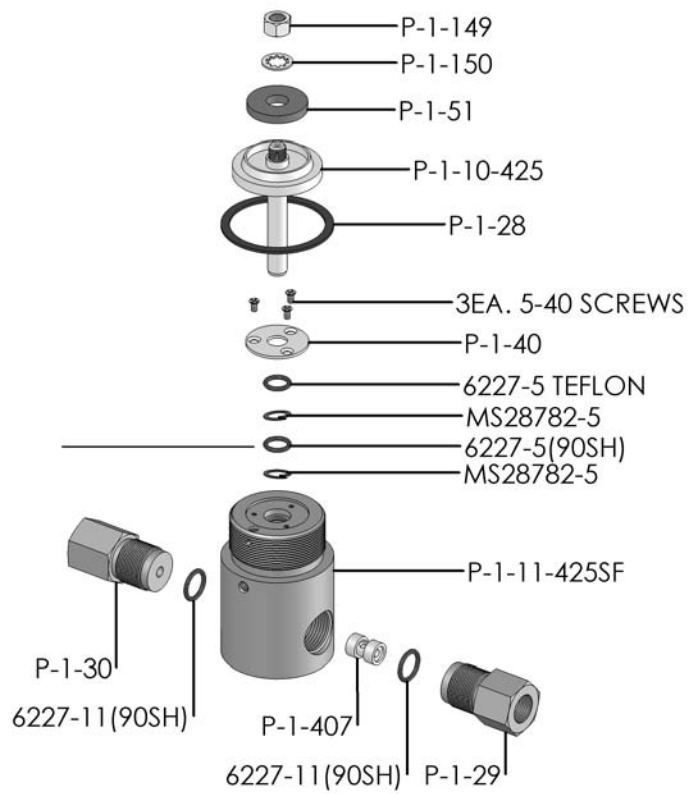

EXPLODED VIEW OF HYDRAULIC ASSEMBLY

HYDRAULIC PRESSURE-PSI	AIR PSI			APPROXIMATE RATE OF DISCHARGE-CIPM
	60	80	100	
0	20	24	26	
1,000				
2,000				
5,000	14	15	16	
6,000				
7,000				
8,000				
9,000				
10,000	11	13	15	
12,500				
15,000	10	12	13	
20,000	9	11	12	
25,000	6	8	10	
30,000	0	6	8	
40,000		0	3	
50,000			0	

AZ-1 MODEL PUMP / PARTS LIST

EXPLODED VIEW OF AIR MOTOR

P-1-113

