

PARTS LIST FOR AZ-1-36SF

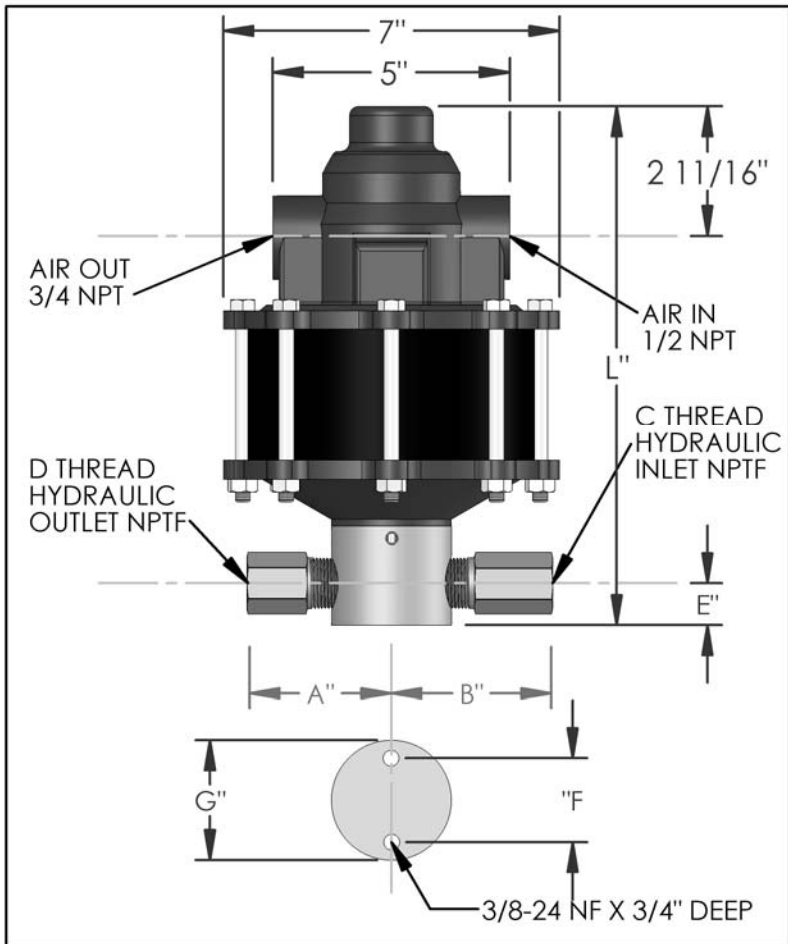

DIMENSIONS (ins./mm)							
L	A	B	C	D	E	F	G
10-7/8	3	3-3/8	1/2	1/2	7/8	1-3/4	2-1/2
276	76	86			22	44	64

HYD. PISTON DIA. (ins.)	0.875
HYD. PISTON AREA (ins.)	0.6013
VOLUME PER STROKE (ci.)	0.766

Pump may be mounted in any position. (vertical Preferred) if mounted in an inverted position, drill a 1/16" hole in head or install a drain cock to release any fluid that may accumulate.

AIR PRESSURE-PSI	10	20	30	40	50	60	70	80	90	100
HYDRAULIC PRESSURE-PSI	250	600	1,000	1,400	1,775	2,125	2,475	2,825	3,200	3,625

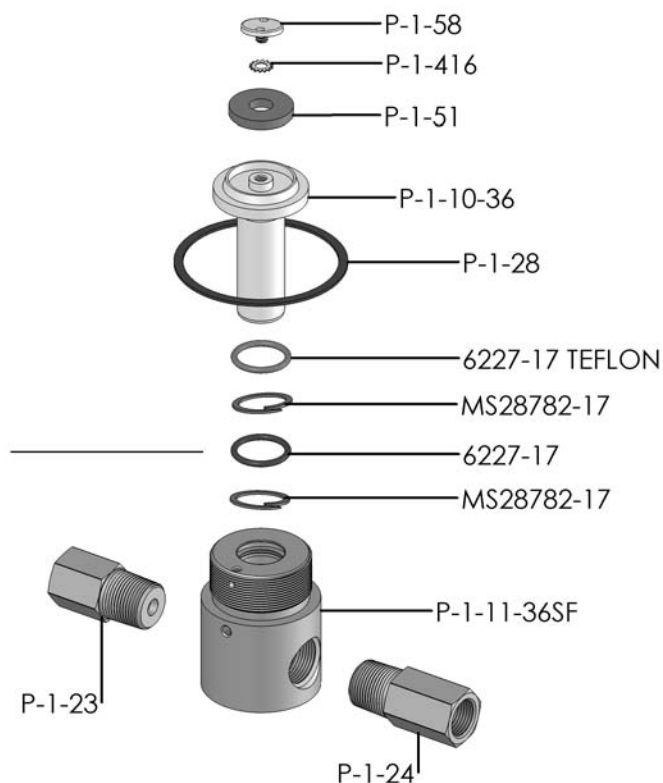

EXPLODED VIEW OF HYDRAULIC ASSEMBLY

AIR PSI		60	80	100	APPROXIMATE RATE OF DISCHARGE-CIPM
HYDRAULIC PRESSURE-PSI	0	253	311	366	
	250				
	500	207	240	268	
	750				
	1,000	168	201	232	
	1,250				
	1,500	134	174	204	
	1,750				
	2,000	73	146	183	
	2,500	0	104	156	
	3,000		0	119	
	3,500			73	
	4,000			0	
	4,500				
	5,000				
	6,000				

AZ-1 MODEL PUMP / PARTS LIST

EXPLODED VIEW OF AIR MOTOR

P-1-113

