

PARTS LIST FOR AZ-1-30SF

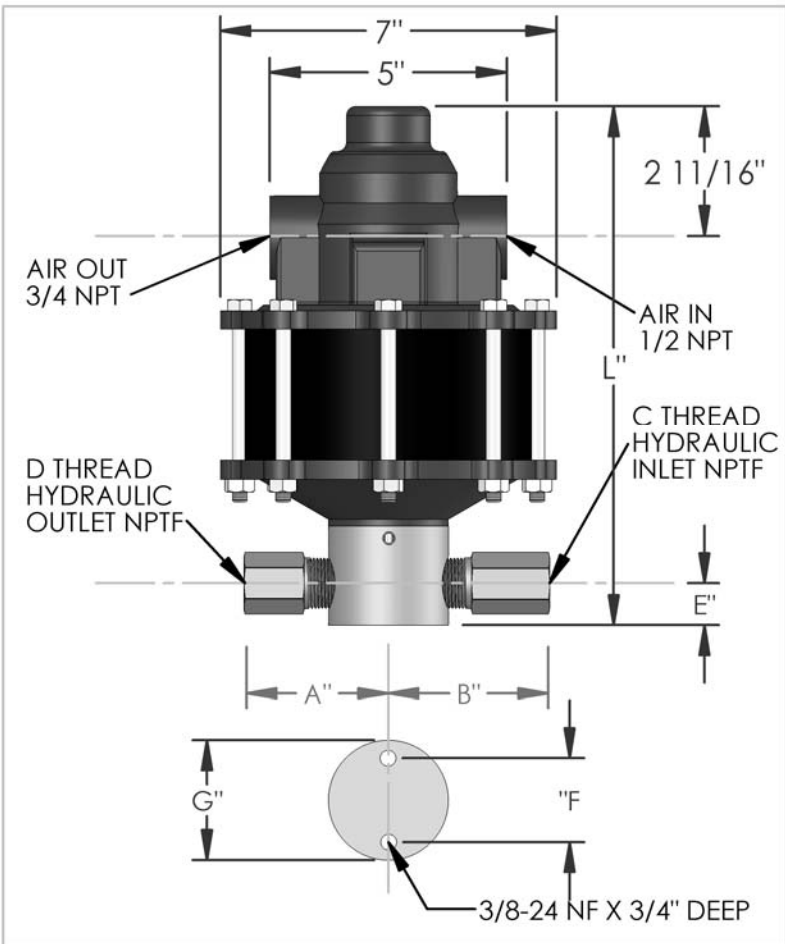

DIMENSIONS (ins./mm)							
L	A	B	C	D	E	F	G
10-7/8	3	3-3/8	1/2	1/2	7/8	1-3/4	2-1/2
276	76	86			22	44	64

HYD. PISTON DIA. (ins.)	0.938
HYD. PISTON AREA (ins.)	0.691
VOLUME PER STROKE (ci.)	0.862

Pump may be mounted in any position. (vertical Preferred) if mounted in an inverted position, drill a 1/16" hole in head or install a drain cock to release any fluid that may accumulate.

AIR PRESSURE-PSI	10	20	30	40	50	60	70	80	90	100
HYDRAULIC PRESSURE-PSI	225	525	875	1,150	1,500	1,775	2,050	2,350	2,700	3,075

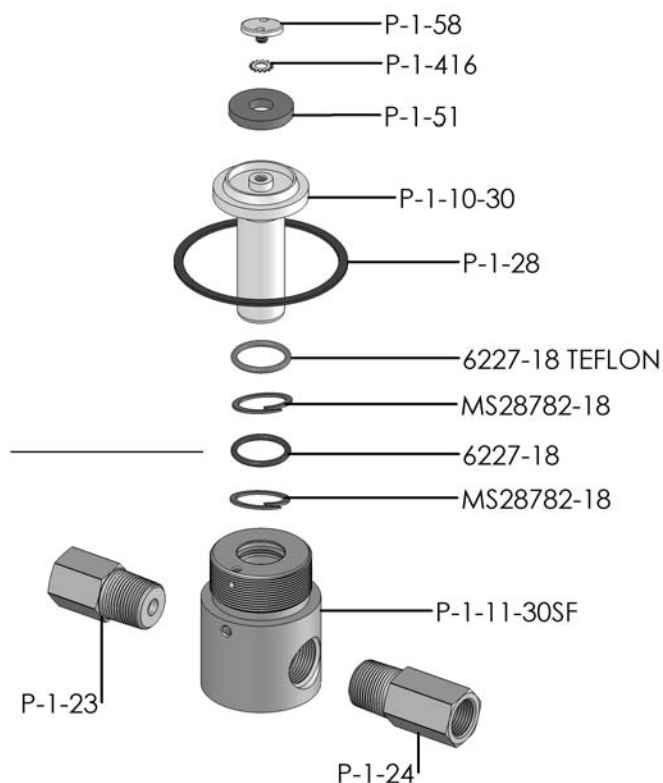

EXPLODED VIEW OF HYDRAULIC ASSEMBLY

AIR PSI		60	80	100	APPROXIMATE RATE OF DISCHARGE-CIPM
HYDRAULIC PRESSURE-PSI	0	305	390	445	
	250				
	500	235	277	311	
	750				
	1,000	183	220	268	
	1,250				
	1,500	131	183	223	
	1,750	49	165	204	
	2,000	0	140	189	
	2,500		0	143	
	3,000			31	
	3,500			0	
	4,000				
	4,500				
	5,000				
	6,000				

AZ-1 MODEL PUMP / PARTS LIST

EXPLODED VIEW OF AIR MOTOR

P-1-113

