

PARTS LIST FOR AZ-1-26SF

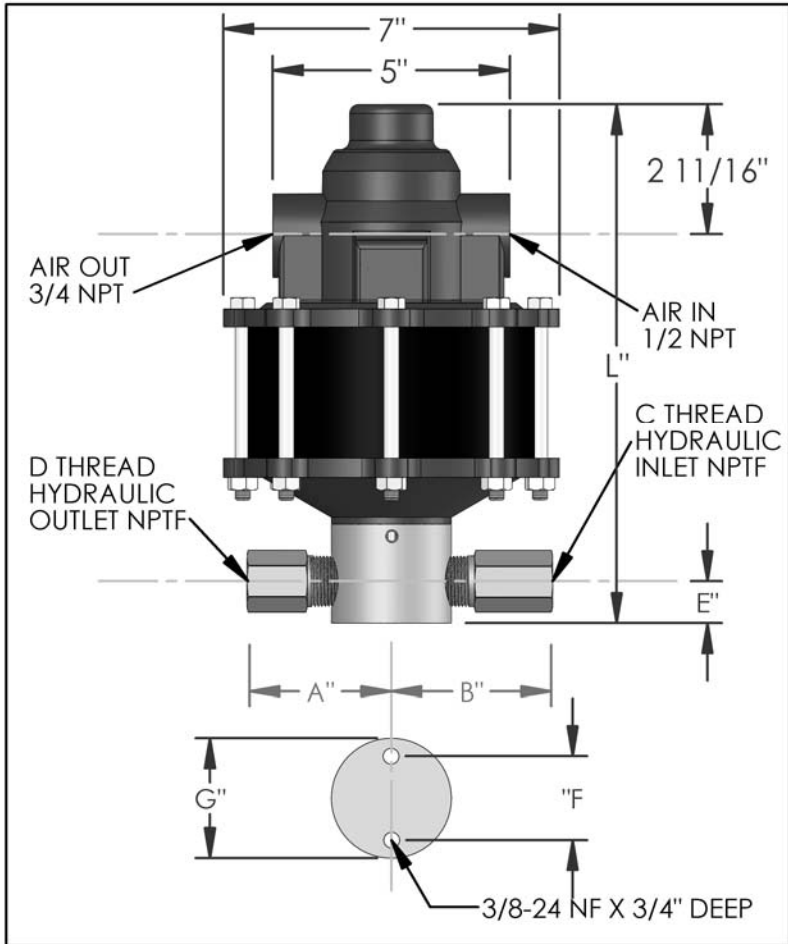

DIMENSIONS (ins./mm)							
L	A	B	C	D	E	F	G
10-7/8	3	3-3/8	1/2	1/2	7/8	1-3/4	2-1/2
276	76	86			22	44	64

HYD. PISTON DIA. (ins.)	1.000
HYD. PISTON AREA (ins.)	0.7854
VOLUME PER STROKE (ci.)	0.982

Pump may be mounted in any position. (vertical Preferred) if mounted in an inverted position, drill a 1/16" hole in head or install a drain cock to release any fluid that may accumulate.

AIR PRESSURE-PSI	10	20	30	40	50	60	70	80	90	100
HYDRAULIC PRESSURE-PSI	200	475	750	1,000	1,300	1,550	1,800	2,000	2,350	2,625

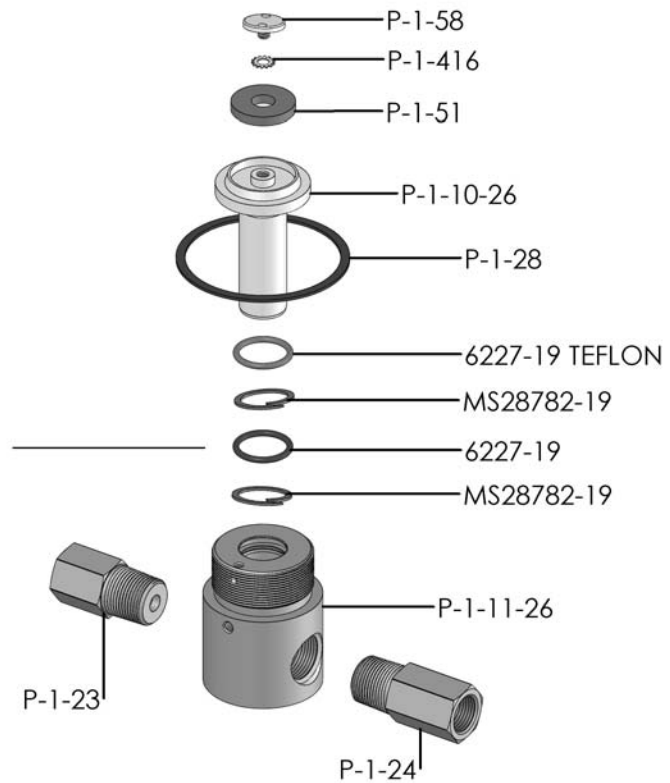

EXPLODED VIEW OF HYDRAULIC ASSEMBLY

AIR PSI		60	80	100	APPROXIMATE RATE OF DISCHARGE-CIPM
HYDRAULIC PRESSURE-PSI	0	361	445	537	
	250				
	500	259	318	357	
	750				
	1,000	201	253	288	
	1,250				
	1,500	85	186	238	
	1,750	0	149	210	
	2,000		88	183	
	2,500		0	74	
	3,000			0	
	3,500				
	4,000				
	4,500				
	5,000				
	6,000				

AZ-1 MODEL PUMP / PARTS LIST

EXPLODED VIEW OF AIR MOTOR

P-1-113

