

PARTS LIST FOR AZ-1-19SF

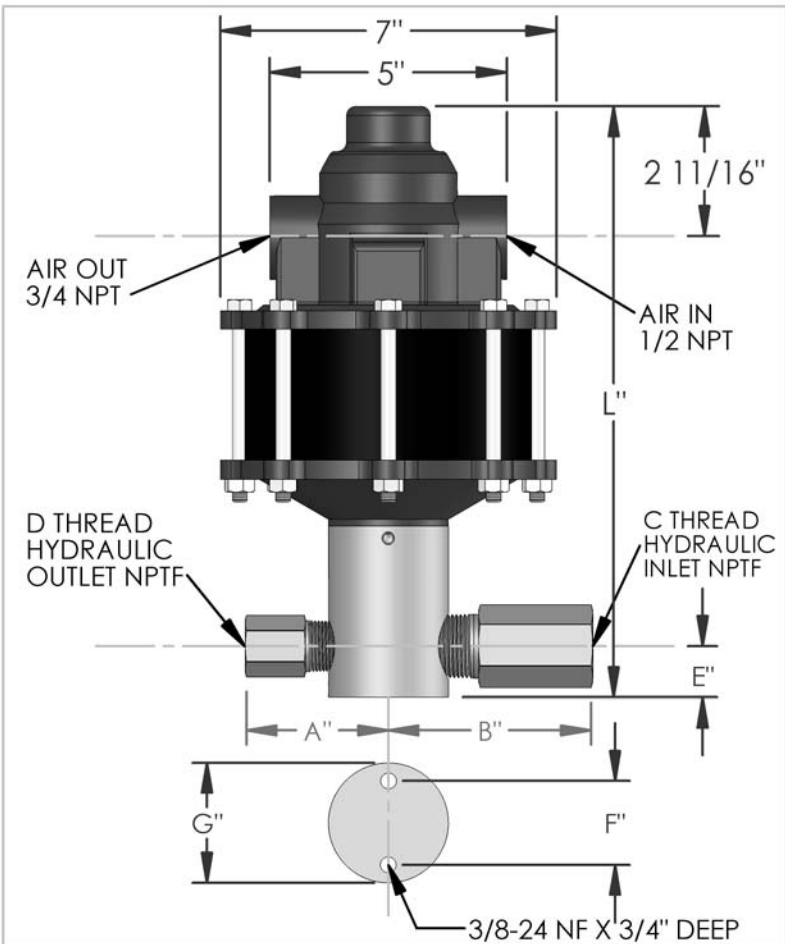

DIMENSIONS (ins./mm)							
L	A	B	C	D	E	F	G
12-5/16	3	4	1	1/2	1	1-3/4	2-1/2
313	76	102			25	44	64

HYD. PISTON DIA. (ins.)	1.188
HYD. PISTON AREA (ins.)	1.1085
VOLUME PER STROKE (ci.)	1.384

Pump may be mounted in any position. (vertical Preferred) if mounted in an inverted position, drill a 1/16" hole in head or install a drain cock to release any fluid that may accumulate.

AIR PRESSURE-PSI	10	20	30	40	50	60	70	80	90	100
HYDRAULIC PRESSURE-PSI	145	330	525	700	925	1,100	1,300	1,500	1,700	1,900

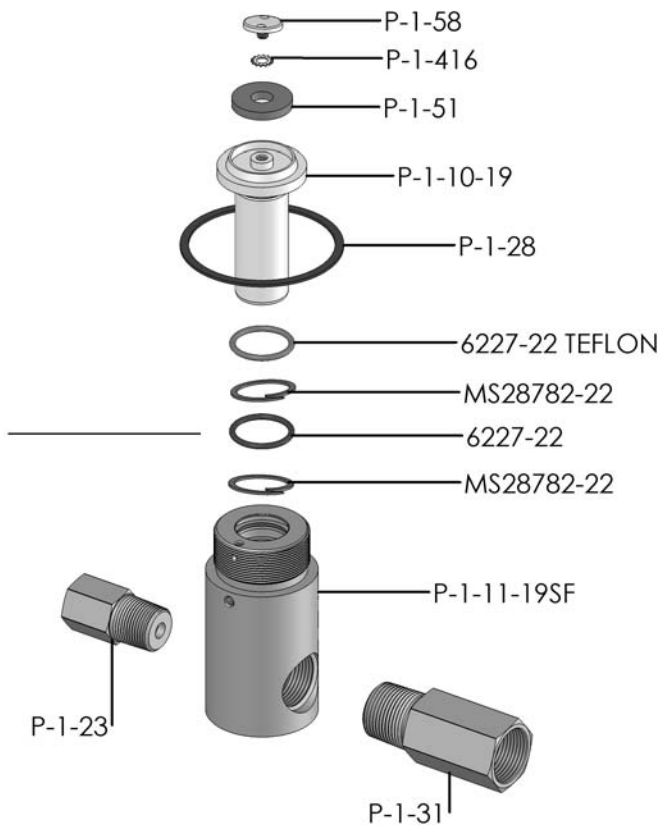

EXPLODED VIEW OF HYDRAULIC ASSEMBLY

AIR PSI		60	80	100	APPROXIMATE RATE OF DISCHARGE-CIPM
HYDRAULIC PRESSURE-PSI	0	561	659	708	
	250	403	488	549	
	500	336	409	476	
	750	278	357	403	
	1,000	180	270	354	
	1,250	0	223	305	
	1,500		63	256	
	1,750		0	153	
	2,000			0	
	2,500				
	3,000				
	3,500				
	4,000				
	4,500				
	5,000				
	6,000				

AZ-1 MODEL PUMP / PARTS LIST

EXPLODED VIEW OF AIR MOTOR

P-1-113

