

# PARTS LIST FOR AZ-1-187

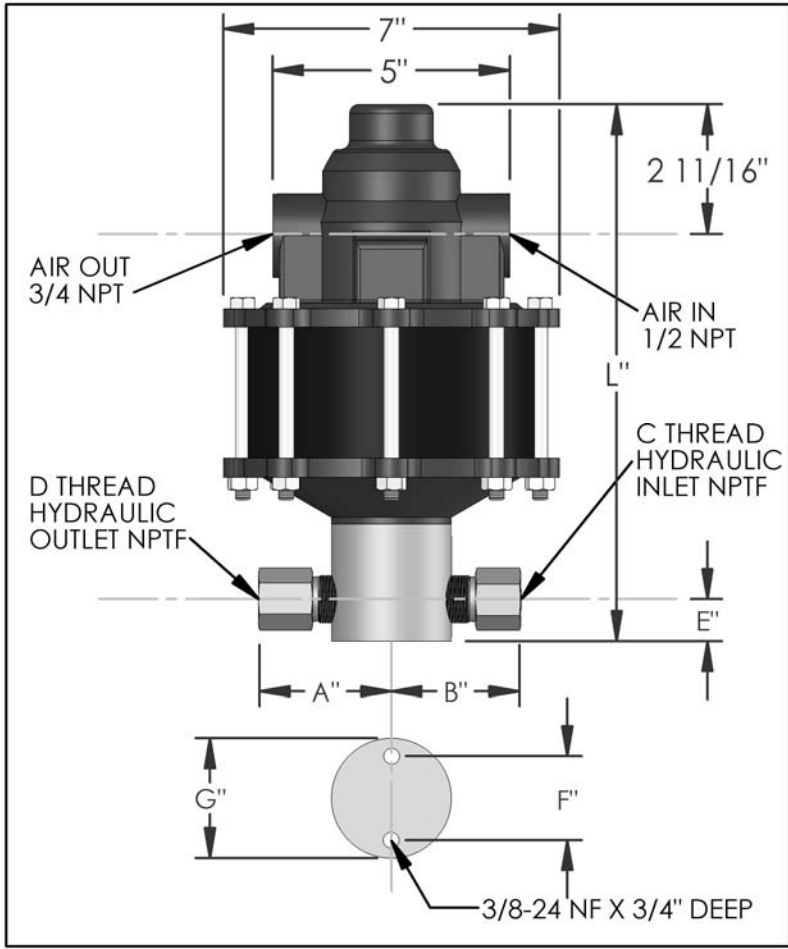

DIMENSIONS (ins./mm)							
L	A	B	C	D	E	F	G
11-1/4	2-1/2	2-5/16	3/8	3/8	7/8	1-3/4	2-1/2
286	64	59			22	44	64

HYD. PISTON DIA. (ins.)	0.375
HYD. PISTON AREA (ins.)	0.1104
VOLUME PER STROKE (ci.)	0.138

Pump may be mounted in any position. (vertical Preferred) if mounted in an inverted position, drill a 1/16" hole in head or install a drain cock to release any fluid that may accumulate.

AIR PRESSURE-PSI	10	20	30	40	50	60	70	80	90	100
HYDRAULIC PRESSURE-PSI	1,400	3,250	5,250	7,250	9,250	11,250	13,250	15,000	17,000	18,750

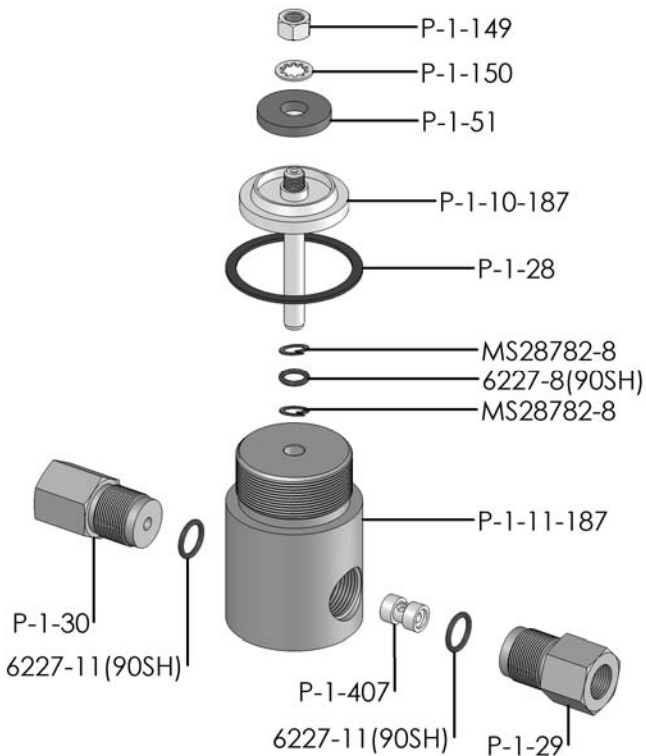

EXPLODED VIEW OF HYDRAULIC ASSEMBLY

HYDRAULIC PRESSURE-PSI	AIR PSI	60	80	100	APPROXIMATE RATE OF DISCHARGE-CIPM
	0	52	62	70	
2,000					
2,500	37	40	46		
3,000					
3,500					
4,000					
4,500					
5,000	31	37	41		
6,000					
7,000					
8,000	24	31	36		
9,000					
10,000	18	27	32		
12,500		23	28		
15,000		3	24		
20,000			0		

# AZ-1 MODEL PUMP / PARTS LIST

## EXPLODED VIEW OF AIR MOTOR

### P-1-113

