

PARTS LIST FOR AZ-1-140SF

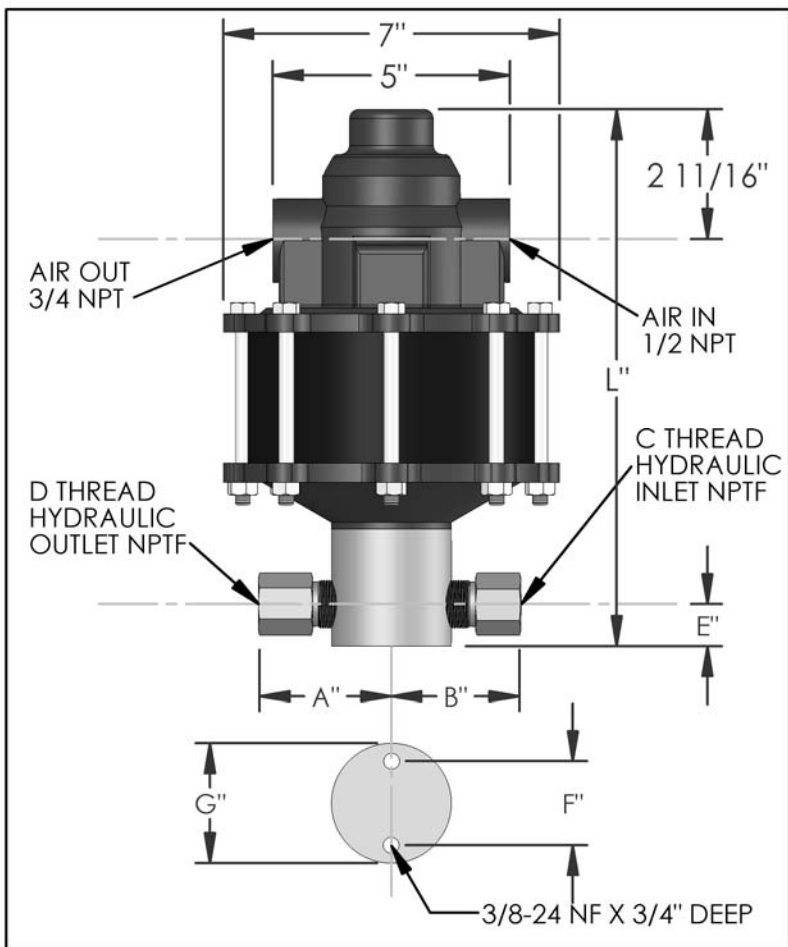

DIMENSIONS (ins./mm)							
L	A	B	C	D	E	F	G
11-1/4	2-1/2	2-5/16	3/8	3/8	7/8	1-3/4	2-1/2
286	64	59			22	44	64

HYD. PISTON DIA. (ins.)	0.438
HYD. PISTON AREA (ins.)	0.1507
VOLUME PER STROKE (ci.)	0.188

Pump may be mounted in any position. (vertical Preferred) if mounted in an inverted position, drill a 1/16" hole in head or install a drain cock to release any fluid that may accumulate.

AIR PRESSURE-PSI	10	20	30	40	50	60	70	80	90	100
HYDRAULIC PRESSURE-PSI	1,100	2,400	3,900	5,400	6,900	8,300	9,800	11,200	12,600	14,000

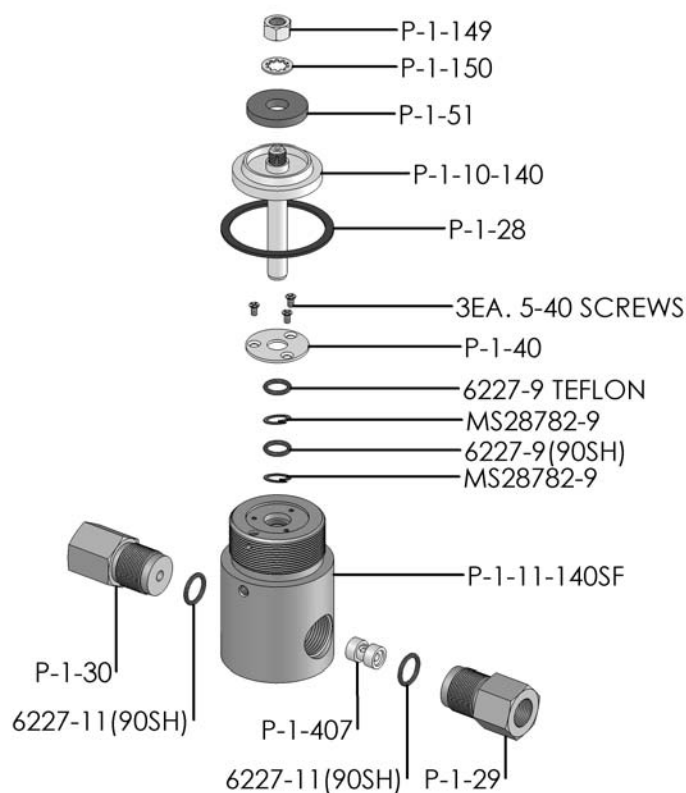

EXPLODED VIEW OF HYDRAULIC ASSEMBLY

HYDRAULIC PRESSURE-PSI	AIR PSI	60	80	100	APPROXIMATE RATE OF DISCHARGE-CIPM
	0	79	86	92	
1,500					
2,000	50	57	61		
2,500					
3,000					
3,500					
4,000	41	51	56		
4,500					
5,000					
6,000	33	42	50		
7,000					
8,000	17	35	43		
9,000					
10,000	0	23	37		
12,500		0	29		
15,000			0		

AZ-1 MODEL PUMP / PARTS LIST

EXPLODED VIEW OF AIR MOTOR

P-1-113

