

# PARTS LIST FOR AZ-1-12SF

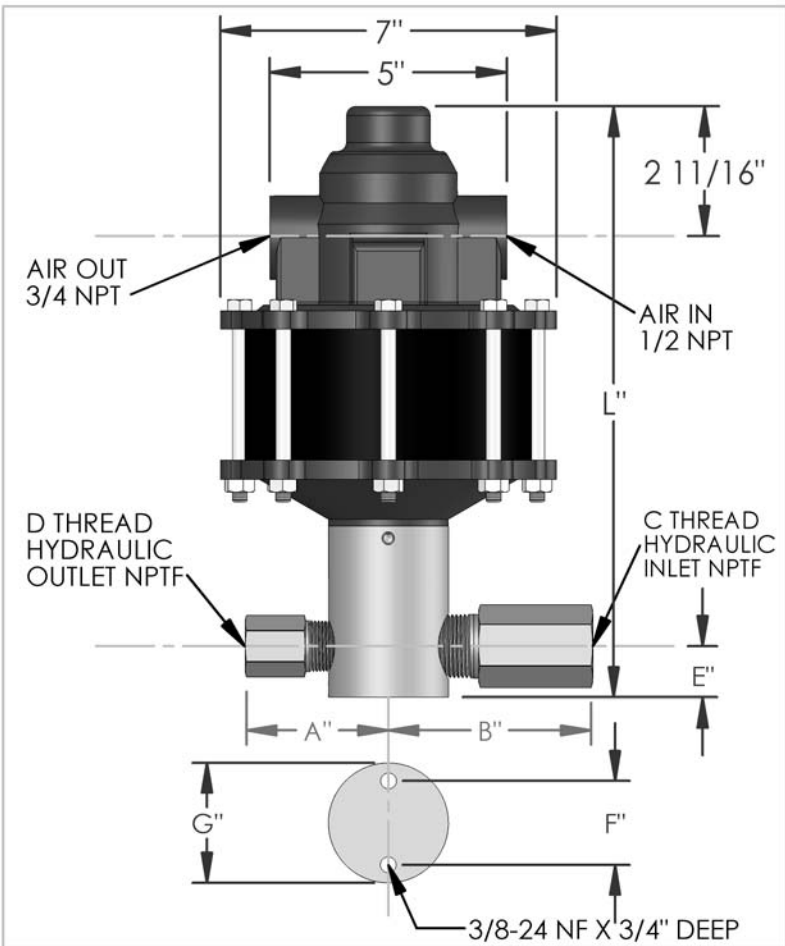

DIMENSIONS (ins./mm)							
L	A	B	C	D	E	F	G
12-5/16	3	4	1	1/2	1	1-3/4	2-1/2
313	76	102			25	44	64

HYD. PISTON DIA. (ins.)	1.500
HYD. PISTON AREA (ins.)	1.7671
VOLUME PER STROKE (ci.)	2.210

Pump may be mounted in any position. (vertical Preferred) if mounted in an inverted position, drill a 1/16" hole in head or install a drain cock to release any fluid that may accumulate.

AIR PRESSURE-PSI	10	20	30	40	50	60	70	80	90	100
HYDRAULIC PRESSURE-PSI	90	200	340	450	560	700	850	980	1,100	1,225

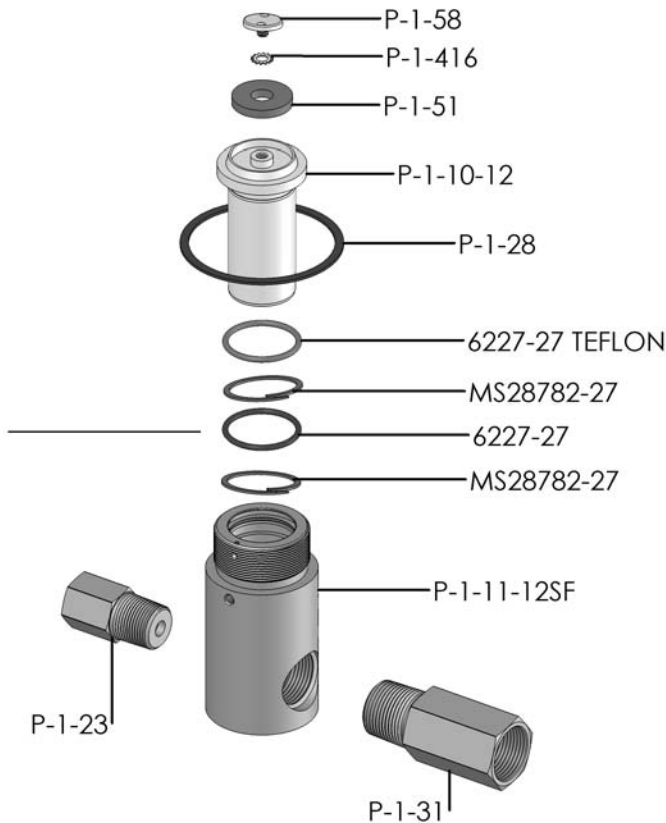

EXPLODED VIEW OF HYDRAULIC ASSEMBLY

AIR PSI	60	80	100	APPROXIMATE RATE OF DISCHARGE-CIPM
0	854	1000	1116	
250	488	613	695	
500	342	522	622	
750	0	342	450	
1,000		0	307	
1,250			0	
1,500				
1,750				
2,000				
2,500				
3,000				
3,500				
4,000				
4,500				
5,000				
6,000				

# AZ-1 MODEL PUMP / PARTS LIST

## EXPLODED VIEW OF AIR MOTOR

### P-1-113

