

# PARTS LIST FOR AZ-1-12B

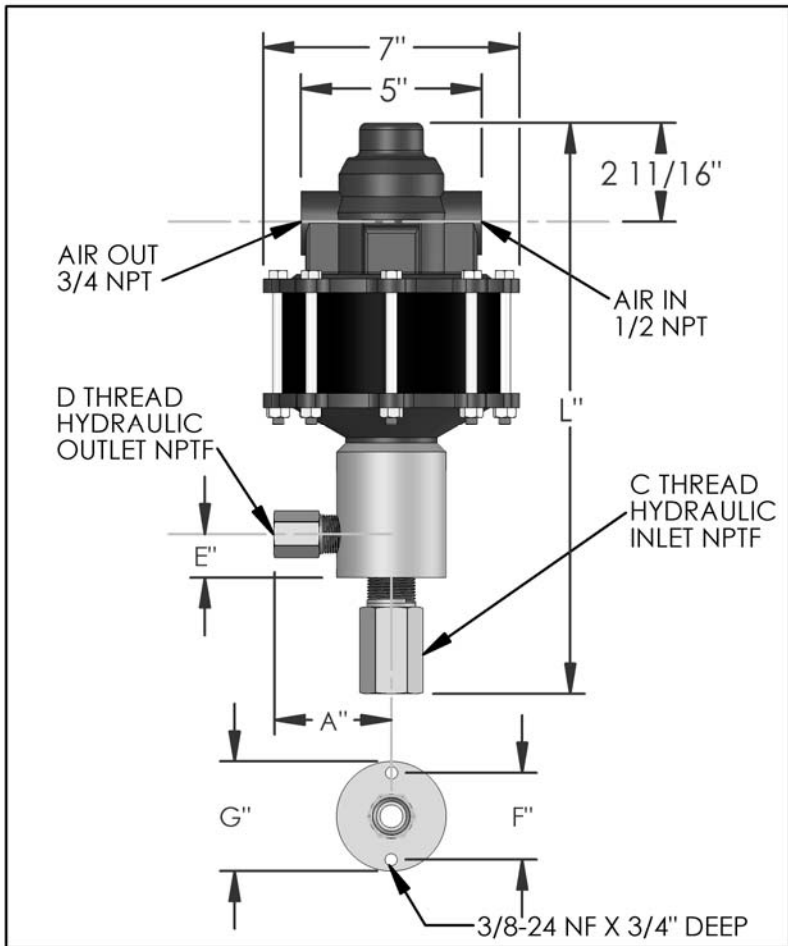

DIMENSIONS (ins./mm)							
L	A	B	C	D	E	F	G
15-13/16	3-5/16	N/A	1	1/2	1-3/16	2-3/8	3
402	84	N/A			30	60	76

HYD. PISTON DIA. (ins.)	1.500
HYD. PISTON AREA (ins.)	1.7671
VOLUME PER STROKE (ci.)	2.210

Pump may be mounted in any position. (vertical Preferred) if mounted in an inverted position, drill a 1/16" hole in head or install a drain cock to release any fluid that may accumulate.

AIR PRESSURE-PSI	10	20	30	40	50	60	70	80	90	100
HYDRAULIC PRESSURE-PSI	90	200	340	450	560	700	850	980	1,100	1,225

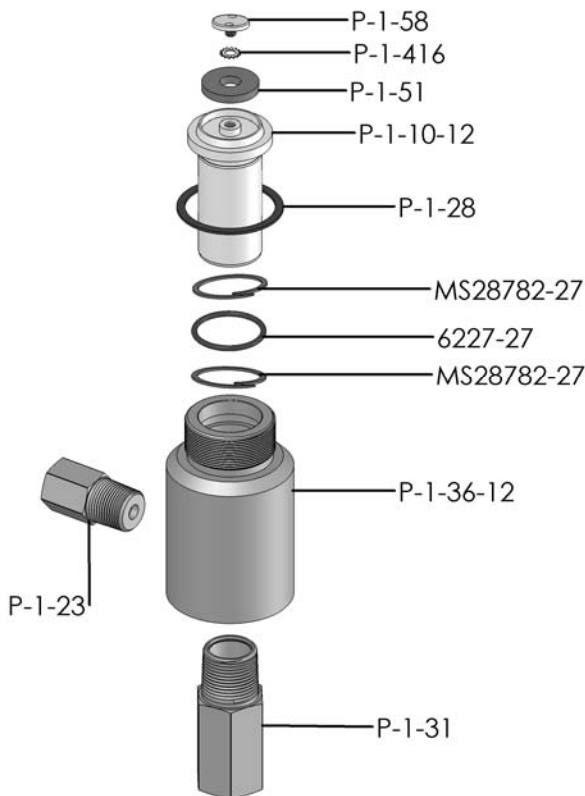

HYDRAULIC PRESSURE-PSI	AIR PSI	60	80	100	APPROXIMATE RATE OF DISCHARGE-CIPM
	0	854	1000	1116	
250	488	613	695		
500	342	522	622		
750	0	342	450		
1,000		0	307		
1,250			0		
1,500					
1,750					
2,000					
2,500					
3,000					
3,500					
4,000					
4,500					
5,000					
6,000					

EXPLODED VIEW OF HYDRAULIC ASSEMBLY

# AZ-1 MODEL PUMP / PARTS LIST

## EXPLODED VIEW OF AIR MOTOR

### P-1-113

