

# PARTS LIST FOR AZ-1-10SF

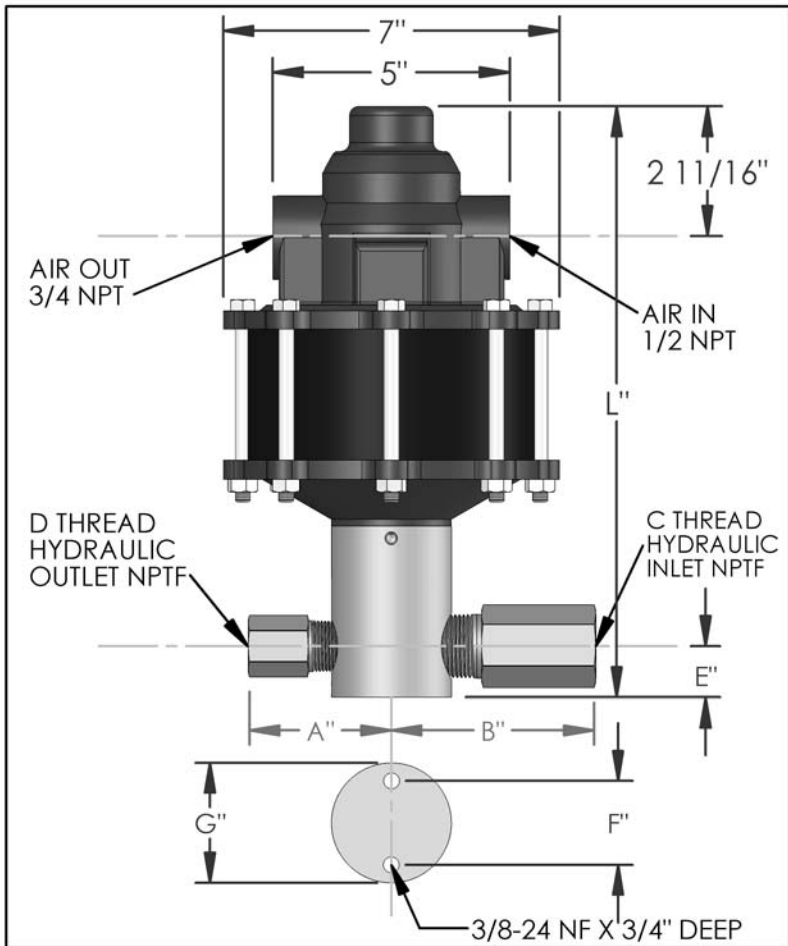

DIMENSIONS (ins./mm)							
L	A	B	C	D	E	F	G
12-5/16	3	4	1	1/2	1	1-3/4	2-1/2
313	76	102			25	44	64

HYD. PISTON DIA. (ins.)	1.625
HYD. PISTON AREA (ins.)	2.0739
VOLUME PER STROKE (ci.)	2.58

Pump may be mounted in any position. (vertical Preferred) if mounted in an inverted position, drill a 1/16" hole in head or install a drain cock to release any fluid that may accumulate.

AIR PRESSURE-PSI	10	20	30	40	50	60	70	80	90	100
HYDRAULIC PRESSURE-PSI	80	180	285	385	490	590	690	795	900	1,000

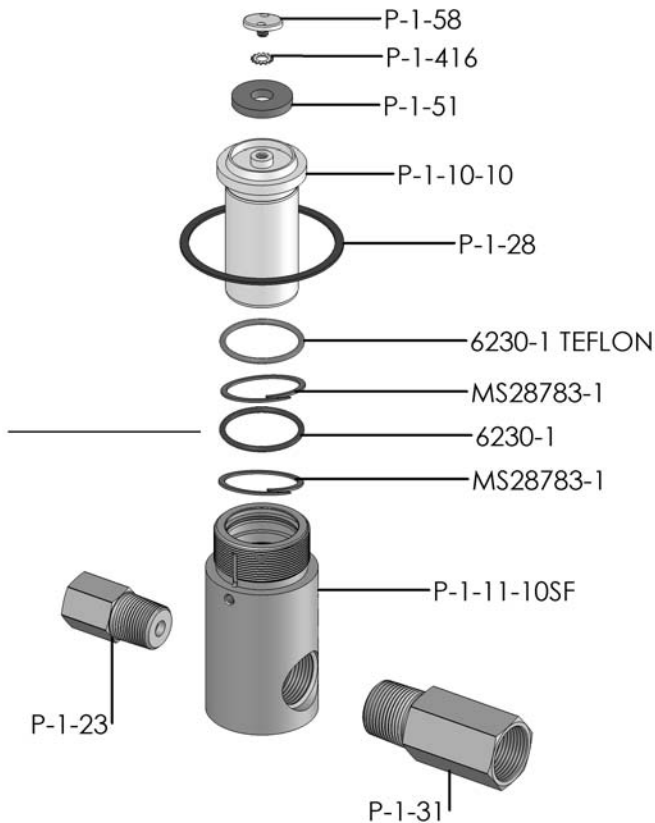

EXPLODED VIEW OF HYDRAULIC ASSEMBLY

AIR PSI	60	80	100	APPROXIMATE RATE OF DISCHARGE-CIPM
0	976	1263	1409	
250	647	830	903	
500	372	598	732	
750	0	238	537	
1,000		0	0	
1,250				
1,500				
1,750				
2,000				
2,500				
3,000				
3,500				
4,000				
4,500				
5,000				
6,000				

# AZ-1 MODEL PUMP / PARTS LIST

## EXPLODED VIEW OF AIR MOTOR

### P-1-113

