

PARTS LIST FOR AZ-1-10B

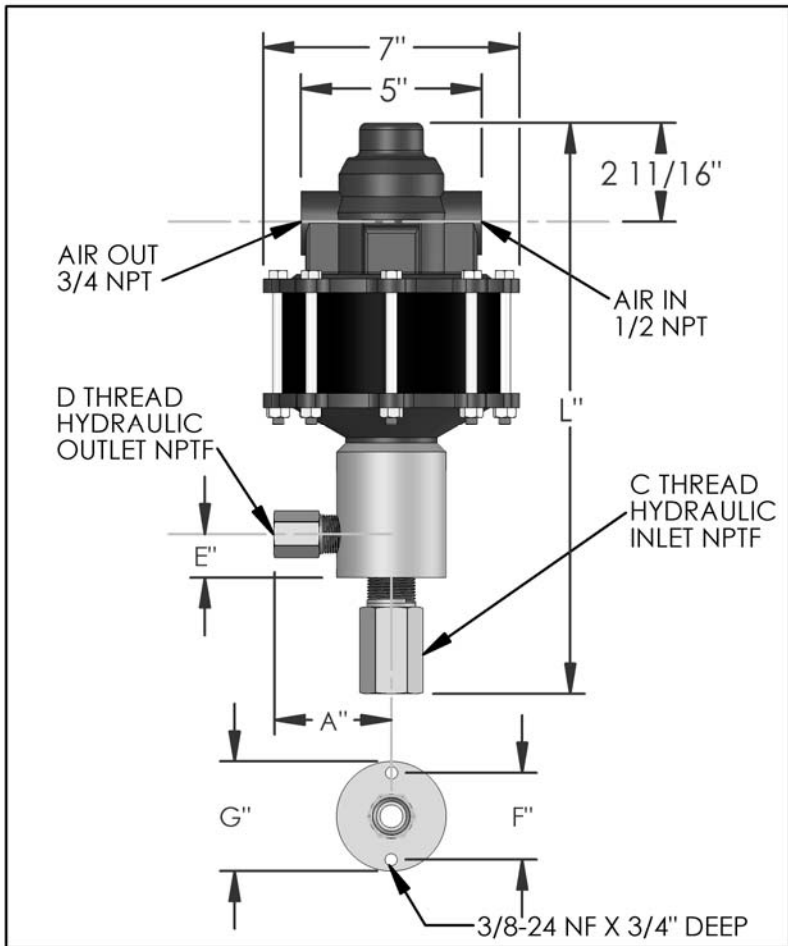

| DIMENSIONS (ins./mm) | | | | | | | |
|----------------------|--------|-----|---|-----|--------|-------|----|
| L | A | B | C | D | E | F | G |
| 15-13/16 | 3-5/16 | N/A | 1 | 1/2 | 1-3/16 | 2-3/8 | 3 |
| 402 | 84 | N/A | | | 30 | 60 | 76 |

| | |
|-------------------------|--------|
| HYD. PISTON DIA. (ins.) | 1.625 |
| HYD. PISTON AREA (ins.) | 2.0739 |
| VOLUME PER STROKE (ci.) | 2.58 |

Pump may be mounted in any position. (vertical Preferred) if mounted in an inverted position, drill a 1/16" hole in head or install a drain cock to release any fluid that may accumulate.

| AIR PRESSURE-PSI | 10 | 20 | 30 | 40 | 50 | 60 | 70 | 80 | 90 | 100 |
|------------------------|----|-----|-----|-----|-----|-----|-----|-----|-----|-------|
| HYDRAULIC PRESSURE-PSI | 80 | 180 | 285 | 385 | 490 | 590 | 690 | 795 | 900 | 1,000 |

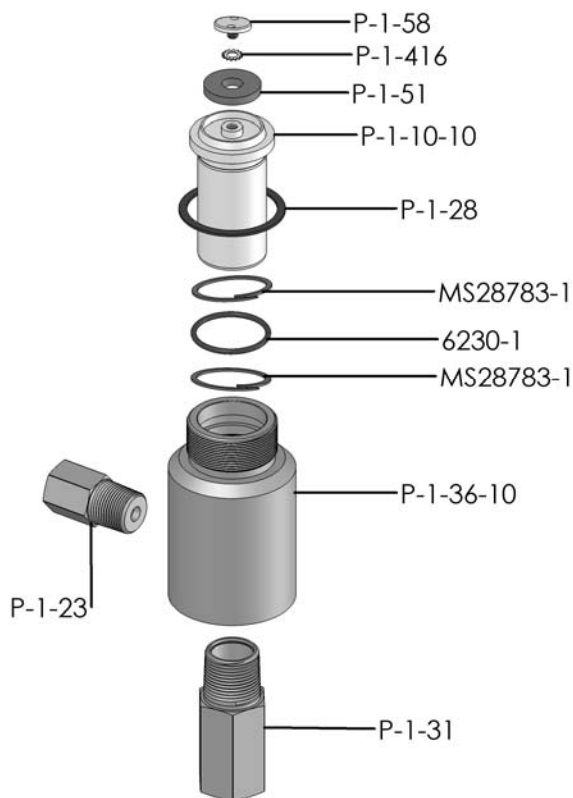

| AIR PSI | | 60 | 80 | 100 | APPROXIMATE RATE OF DISCHARGE-CIPM |
|------------------------|-------|-----|------|------|------------------------------------|
| HYDRAULIC PRESSURE-PSI | 0 | 976 | 1263 | 1409 | |
| | 250 | 647 | 830 | 903 | |
| | 500 | 372 | 598 | 732 | |
| | 750 | 0 | 238 | 537 | |
| | 1,000 | | 0 | 0 | |
| | 1,250 | | | | |
| | 1,500 | | | | |
| | 1,750 | | | | |
| | 2,000 | | | | |
| | 2,500 | | | | |
| | 3,000 | | | | |
| | 3,500 | | | | |
| | 4,000 | | | | |
| | 4,500 | | | | |
| | 5,000 | | | | |
| | 6,000 | | | | |

EXPLODED VIEW OF HYDRAULIC ASSEMBLY

AZ-1 MODEL PUMP / PARTS LIST

EXPLODED VIEW OF AIR MOTOR

P-1-113

