

PARTS LIST FOR AZ-1-107SF

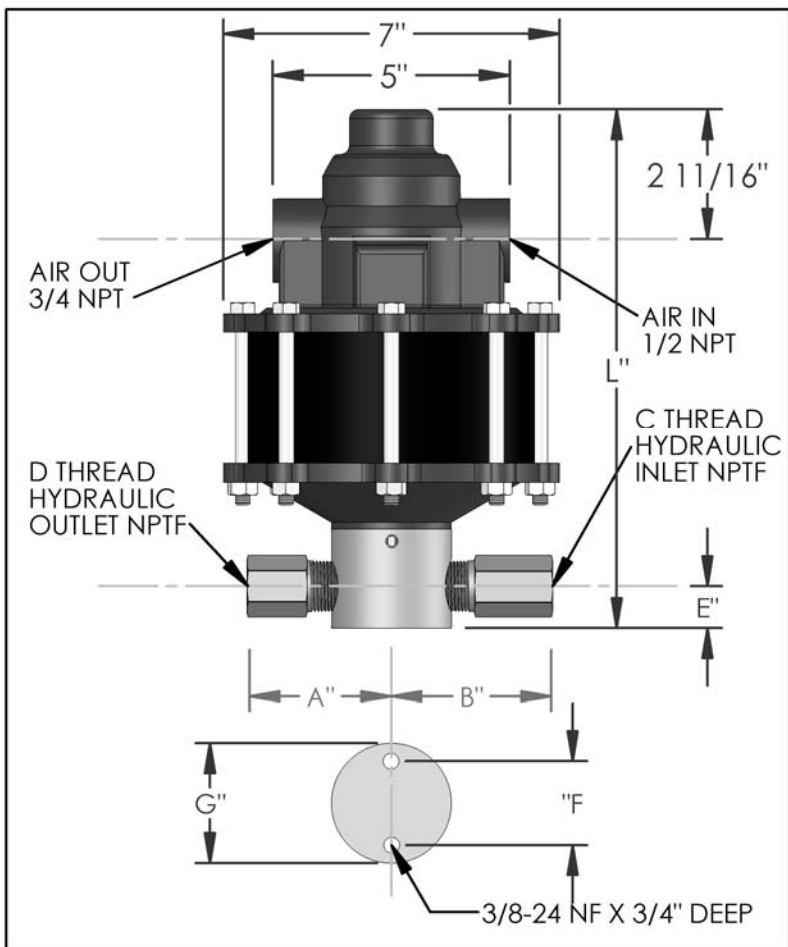

DIMENSIONS (ins./mm)							
L	A	B	C	D	E	F	G
10-7/8	3	3-3/8	1/2	1/2	7/8	1-3/4	2-1/2
276	76	86			22	44	64

HYD. PISTON DIA. (ins.)	0.500
HYD. PISTON AREA (ins.)	0.1963
VOLUME PER STROKE (ci.)	0.245

Pump may be mounted in any position. (vertical Preferred) if mounted in an inverted position, drill a 1/16" hole in head or install a drain cock to release any fluid that may accumulate.

AIR PRESSURE-PSI	10	20	30	40	50	60	70	80	90	100
HYDRAULIC PRESSURE-PSI	900	2,000	3,150	4,200	5,400	6,400	7,450	8,500	9,700	10,700

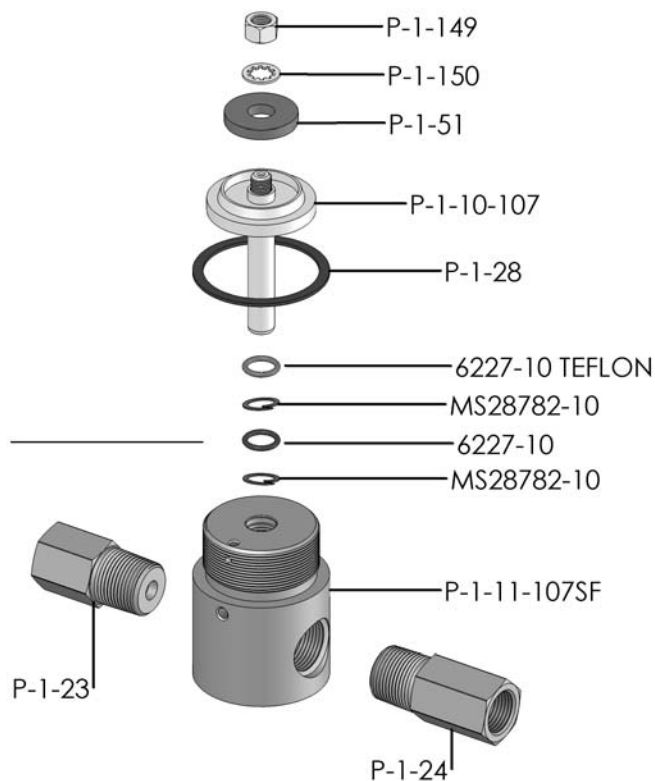

EXPLODED VIEW OF HYDRAULIC ASSEMBLY

AIR PSI		60	80	100	APPROXIMATE RATE OF DISCHARGE-CIPM
HYDRAULIC PRESSURE-PSI	0	95	110	120	
	1,000	69	74	78	
	1,500				
	2,000	61	68	74	
	2,500				
	3,000	53	63	71	
	3,500				
	4,000	46	58	62	
	4,500				
	5,000				
	6,000	26	45	54	
	7,000	0			
	8,000		28	44	
	9,000		0	38	
	10,000			27	
	12,500			0	

AZ-1 MODEL PUMP / PARTS LIST

EXPLODED VIEW OF AIR MOTOR

P-1-113

