

PARTS LIST FOR AZ-2-144LPS

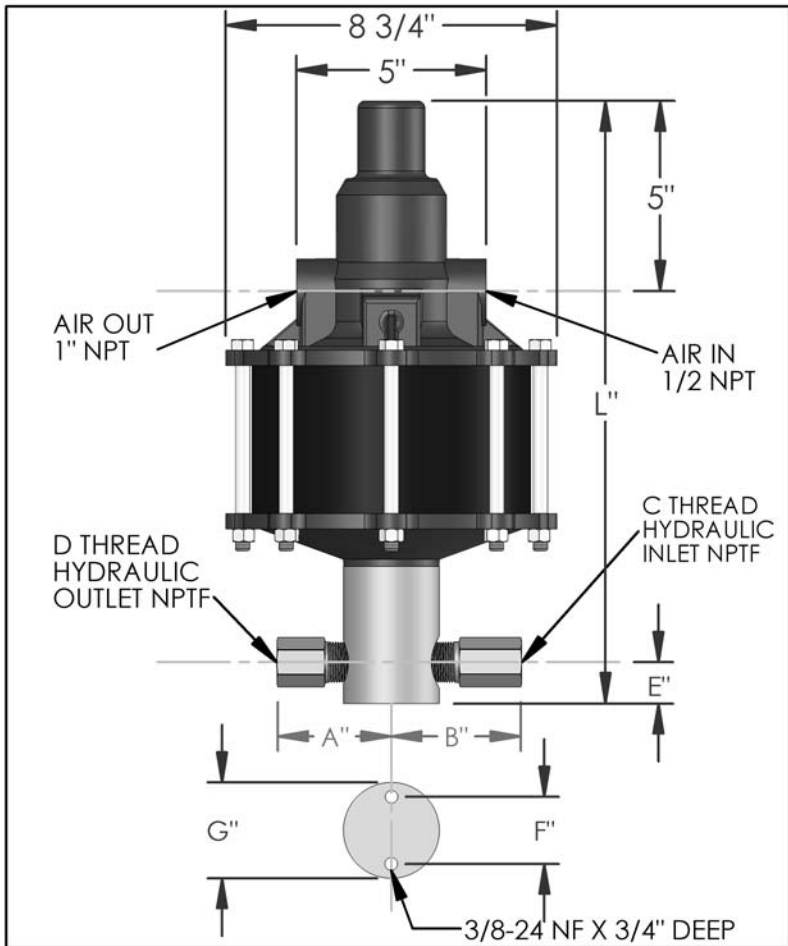

DIMENSIONS (ins./mm)							
L	A	B	C	D	E	F	G
15-3/4	3	3-3/8	1/2	1/2	7/8	1-3/4	2-1/2
400	76	86			22	44	64

HYD. PISTON DIA. (ins.)	0.563
HYD. PISTON AREA (ins.)	0.2489
VOLUME PER STROKE (ci.)	0.621

Pump may be mounted in any position. (vertical Preferred) if mounted in an inverted position, drill a 1/16" hole in head or install a drain cock to release any fluid that may accumulate.

AIR PRESSURE-PSI	10	20	30	40	50	60	70	80	90	100	110
HYDRAULIC PRESSURE-PSI	1,100	2,600	4,200	5,550	7,100	8,500	10,000	11,500	12,950	14,400	15,750

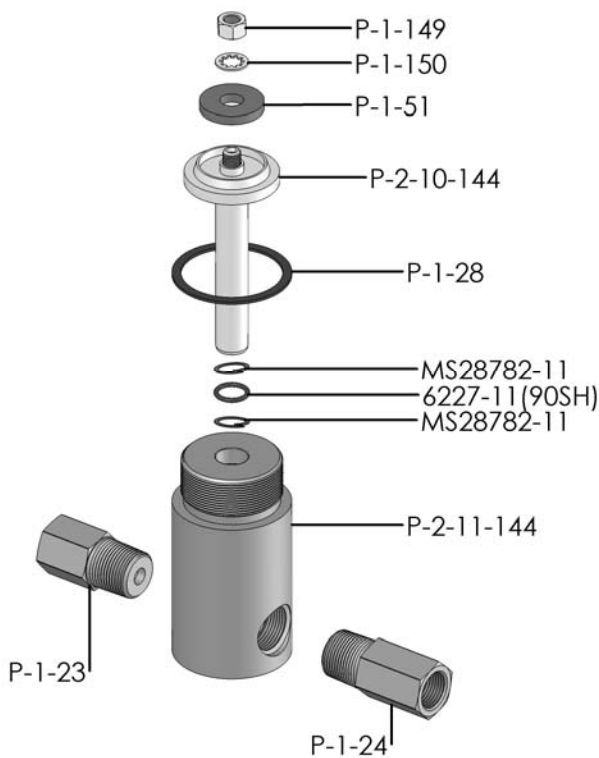

EXPLODED VIEW OF HYDRAULIC ASSEMBLY

AIR PSI		60	80	100	APPROXIMATE RATE OF DISCHARGE-CIPM
HYDRAULIC PRESSURE-PSI	0	119	140	165	
	2,000	101	116	125	
	2,500				
	3,000				
	3,500				
	4,000	81	98	108	
	4,500				
	5,000				
	6,000	64	82	93	
	7,000				
	8,000	28	67	80	
	9,000	0			
	10,000		46	68	
	12,500		0	47	
	15,000			0	
	20,000				

AZ-2 MODEL PUMP / PARTS LIST

EXPLODED VIEW OF AIR MOTOR

P-2-113LPS

