

PARTS LIST FOR AZ-1-.5SF

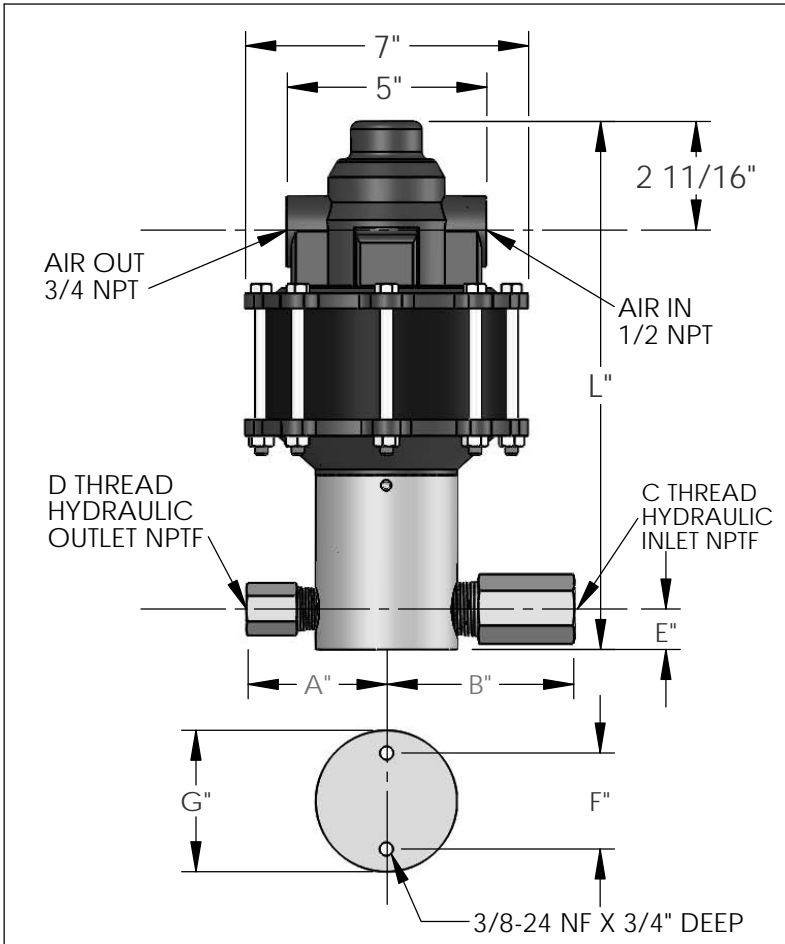

DIMENSIONS (ins./mm)							
L	A	B	C	D	E	F	G
13-1/8	3-1/2	4-5/8	1	1/2	1	2-3/8	3-1/2
333	89	117			25	60	89

HYD. PISTON DIA. (ins.)	2.375
HYD. PISTON AREA (ins.)	4.4301
VOLUME PER STROKE (ci.)	5.54

Pump may be mounted in any position. (vertical Preferred) if mounted in an inverted position, drill a 1/16" hole in head or install a drain cock to release any fluid that may accumulate.

AIR PRESSURE-PSI	10	20	30	40	50	60	70	80	90	100
HYDRAULIC PRESSURE-PSI	30	75	130	175	220	270	320	370	415	465

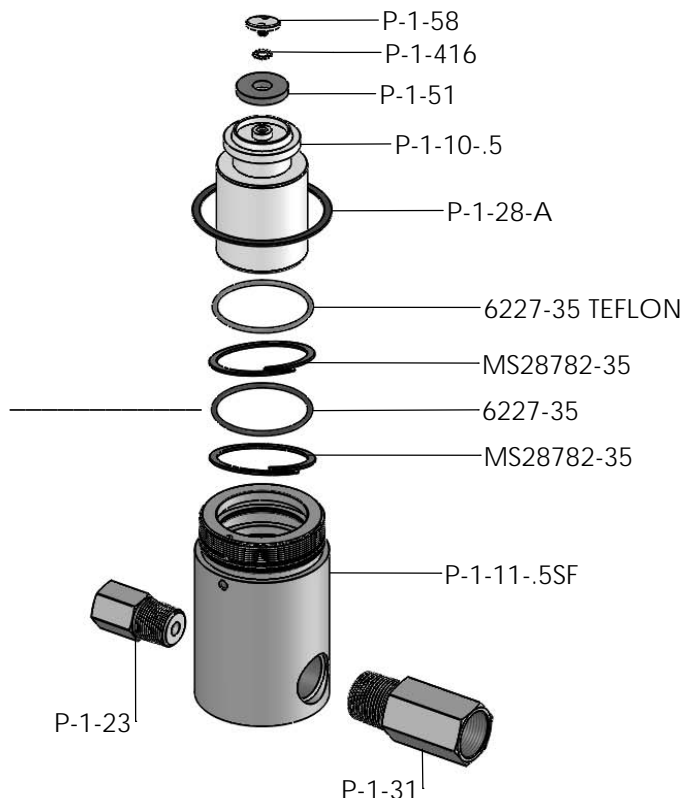

AIR PSI		60	80	100	APPROXIMATE RATE OF DISCHARGE-GPM
HYDRAULIC PRESSURE-PSI	0	6.25	7.3	8	
	100	4.6	5.2	6	
	200	3.3	4.4	5.2	
	300	0	2.4	3.9	
	400		0	1.9	
	500			0	
	600				
	700				

EXPLODED VIEW OF HYDRAULIC ASSEMBLY

AZ-1 MODEL PUMP / PARTS LIST

EXPLODED VIEW OF AIR MOTOR

P-1-113

